

## High Rate Valve Regulated SLA Batteries

### Features

- Sealed and Maintenance Free
- Safety Valve for Ultimate Safety; Prevents Overpressure
- Good Deep Discharge Recovery Performance
- Low Self Discharge Characteristics
- Highly Resistant to Vibration and Shock



TPBAT12-9  
12V 8.5Ah SLA AGM Battery

### Applications

- Remote Equipment Power
- Surveillance Cameras
- Wireless Base Stations
- Medical Equipment
- Remote Sensors
- Backup Power Systems

### Description

The TPBAT12-9 high rate valve regulated sealed lead acid (VRLA) batteries have been developed for long term operation in harsh environments. The small battery uses absorbent glass mat (AGM) technology which provides for unsurpassed reliability over wide temperature ranges. The batteries can be installed in any position without affecting their performance or reliability.

The combination of advanced electrode and electrolyte formulations provide higher power output than normal batteries of the same physical size. The TPBAT12-9 has F2 type .25" spade connectors.

### Specifications

| TPBAT12-9                          |  |
|------------------------------------|--|
| <b>Voltage</b>                     | 12V  |
| <b>Capacity (20hr Rate)</b>        | 8.5Ah to 10.5V, 9aH to 10.0V                                 |
| <b>Float Life</b>                  | 5 Years  |
| <b>Type / Technology</b>           | Valve Regulated Sealed Lead Acid / Absorbent Glass Mat (AGM) |
| <b>Capacity vs Temperature</b>     | 40°C=102%; 0°C=85%, -15°C=65%                                |
| <b>Self Discharge (25°C)</b>       | <3% per month  |
| <b>Charge Voltage (-30mV / °C)</b> | 14.4 to 15V ; Max Current 2.7A                               |
| <b>Float Voltage (-20mV / °C)</b>  | 13.6 to 13.8V  |
| <b>Operating Temperature</b>       | -40C (-40F) to +60C (140F)                                   |
| <b>Housing</b>                     | ABS (UL94HB)   |
| <b>Dimensions</b>                  | 151 x 65 x 95mm<br>(5.9 x 2.6 x 3.7")                        |
| <b>Weight</b>                      | 2.5kg (5.5lb)  |
| <b>Warranty</b>                    | 2 Years  |

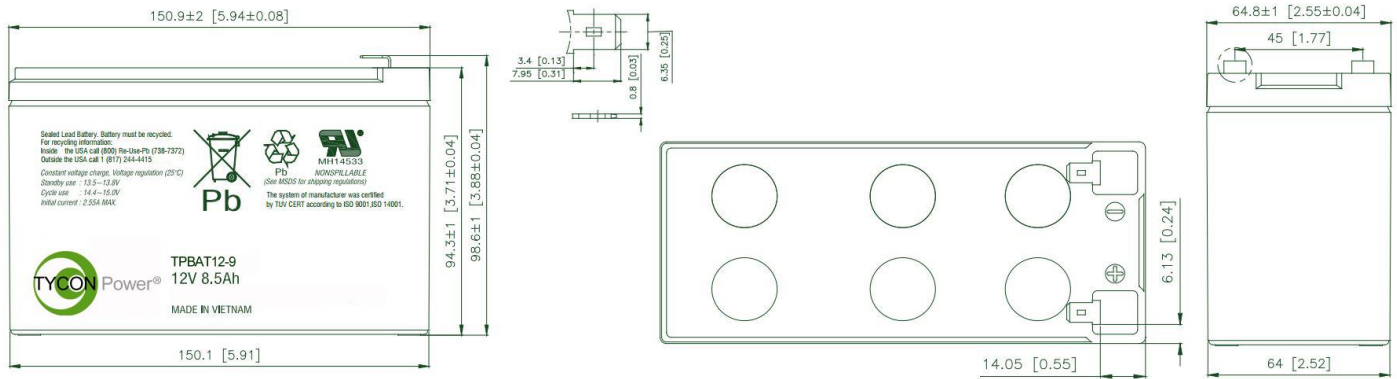
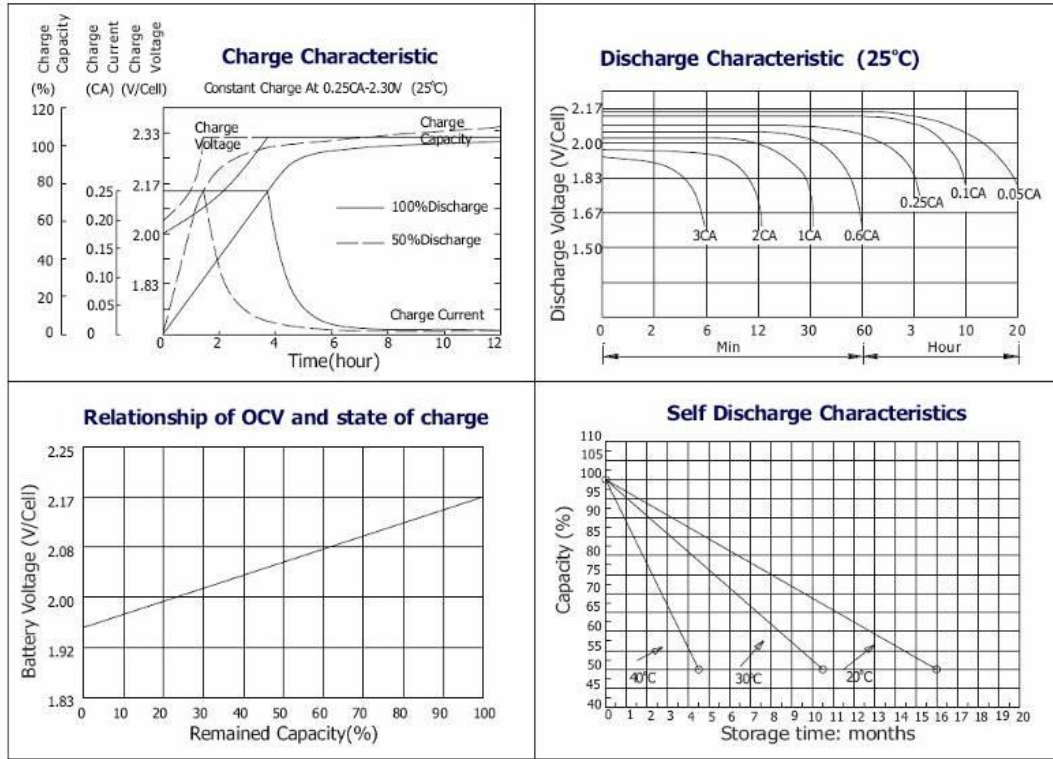

**System Ordering:**

**TPBAT12-9** 12V 8.5Ah Valve Regulated Sealed Lead Acid AGM Battery

**For further information contact:**

[Tyconpower.com](http://Tyconpower.com)

