



UPS-PL

UPSPro[®] Outdoor Backup Power System

- Wireless Base Stations and Client Devices
- Surveillance Cameras
- Mission Critical Backup Power
- Remote Sensors



Congratulations! on your purchase of the UPSPro[®] Outdoor UPS backup power system. Please take a moment to review this Qwik Install Guide before assembly or battery installation.



DANGER! Avoid Powerlines! You Can Be Killed!

When following the instructions in this guide take extreme care to avoid contact with overhead power lines, lights and power circuits. Contact with power lines, lights or power circuits may be fatal. We recommend to install no closer than 20 feet to any power lines.

Safety: For your own protection, follow these safety rules.

- **Perform as many functions as possible on the ground**
- **Do not attempt to install on a rainy, windy or snowy day or if there is ice or snow accumulation at the install site or if the site is wet.**
- **Make sure there are no people, pets, etc. below when you are working on a roof or ladder.**



Recommended Tools: Phillips Screwdriver, Flat Blade Screwdriver, 5/16 nut driver



Please help preserve the environment and return used batteries to an authorized depot

Qwik Install

STEP 1: Prepare Enclosure - Attach Battery Brackets

Prepare the Velcro strap and the strap brackets, #5600066. Orient as shown.



Loosen 8 screws holding the mounting plate.

Slide the mounting plate towards you and lift up on the top end of the mounting plate while sliding the #5600066 bracket with Velcro Strap over the end of the mounting plate.

Place the brackets as shown and attach to the mounting plate using Qty 2 #8 x 3/8 pan head self tapping screws.

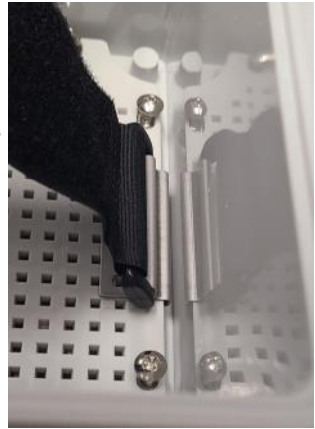

Position the #5600067 Battery Support Brackets ~5" from the top of the enclosure. Allow enough space to accommodate the 2 batteries.

Attach to the mounting plate using Qty 4 #8 x 3/8 pan head self tapping screw.

Route the Velcro straps through the slot in the #5600067 brackets. We recommend not installing the batteries at this time because it makes the enclosure heavy and harder to handle. We suggest installing the batteries once the enclosure is already mounted to a pole or wall.



STEP 2: Prepare Enclosure - Attach Pole Mount Brackets

Caution: Pole mount brackets may have sharp edges, wear gloves.

Attach the pole mount brackets to the back of the enclosure using four flat washers as spacers under the bracket and four flat washers and self tapping screws on top of the bracket per the instructions that came with the enclosure.



STEP 3: Solar Battery Charge Controller Install

The system includes an advanced PWM charge controller with PoE output (SCPOE). Mount the controller to the inside cover using the supplied velcro adhesive strips.

The controller maintains proper charge parameters to extend battery life and enables the system to be Solar Ready™. Solar panels can be added at any time to extend backup time or provide a backup power source to keep the batteries fully charged.

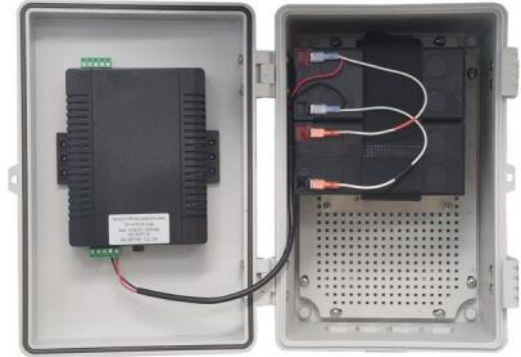

Attach the included battery cable to the controller BAT inputs. (Red to + and Black to -). Don't connect wires to battery until system startup step.

Note: The battery cable is different if 12V or 24V configuration. For 12V, batteries are wired in parallel. If 24V, the batteries are wired in series.

The controller has an RJ45 Passive PoE Output (24V or 48V) and there is also a green wire terminal output on the back of the controller which will be equal to the battery voltage and is also controlled by the Low Voltage Disconnect function of the controller. Wire Terminal output supports 1.5A max.

The kit includes two Cable Gland Feedthroughs. Remove one or two hole plugs in the bottom of the enclosure and replace with one or two cable gland feedthroughs to be used to route external wires.

STEP 4: Enclosure Mounting

Mount the enclosure to a pole using two stainless steel hose clamps. Cut off any extra hose clamp length after tightening to keep a clean install. As an option, the enclosure can also mount to a wall using the included 4 wall mount brackets and user supplied screws.

STEP 5: Battery Install

Insert the batteries by slipping under the Velcro strap and then tightening the strap.

STEP 6: Power Supply Install

The UPSPro® system with SCPOE battery charge controller is designed to be powered over PoE using a passive PoE inserter and AC/DC Power Source.

Install a CAT5 cable between the PoE inserter/Power Supply inside building and the SCPOE controller RJ45 “POE IN” connector. It is highly recommended to protect electronics from lightning/surge damage that the power supply be plugged into a surge protected outlet inside the building. Don't plug in the AC/DC power source until the following System Startup step.

STEP 7: System Startup

Connect Battery wire negatives (Black) to battery terminal negatives (Black). Connect Battery wire positives (Red) to battery terminal positives (Red). If battery voltage is >12V (SCPOE-12xx) or >24V (SCPOE-24xx) the controller should be powered up.

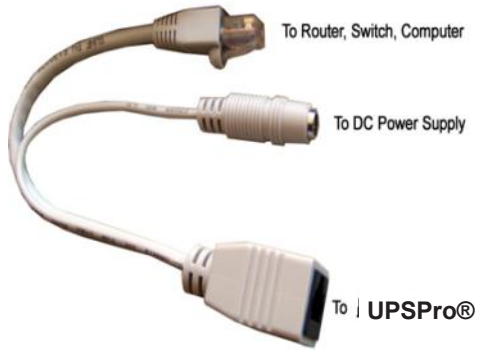

After the controller is connected to the batteries, you can power up the power supply that is inside the building. You should see the POE, CHA and LOA lights lit on the controller.

POE means that there is PoE power detected on POE IN.

CHA means the battery is charging.

LOA means the load output is ON. POE OUT is on, wire terminal is ON.

STEP 8: Make sure the lid gasket is clean and free from any particles, then close and latch the cover, making sure that wires are clear of the gasket area. There is a small combination lock included if you want to prevent someone from opening the enclosure without your knowledge.

SPECIFICATION SUMMARY

Subject to change without notice

Model #	Battery Volts	Battery Capacity	Storage Capacity	Backup Time at 25W Avg Load	Passive PoE Out (30W)
UPS-PL1224-18	12VDC	18Ah	216Wh	4.5hrs	24V
UPS-PL1248-18	12VDC	18Ah	216Wh	4.5hrs	48V
UPS-PL2424-18	24VDC	18Ah	216Wh	4.5hrs	24V
UPS-PL2448-18	24VDC	18Ah	216Wh	4.5hrs	48V

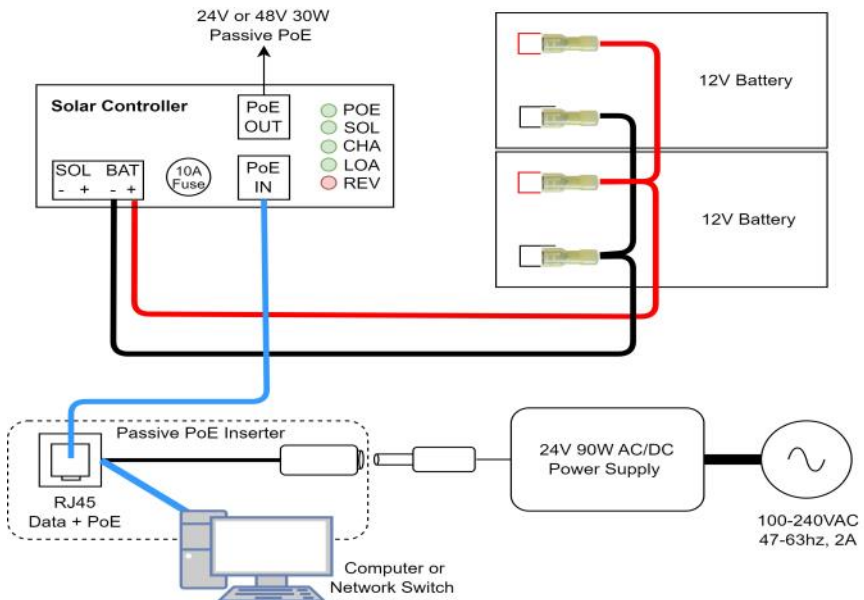

12V Battery Configuration

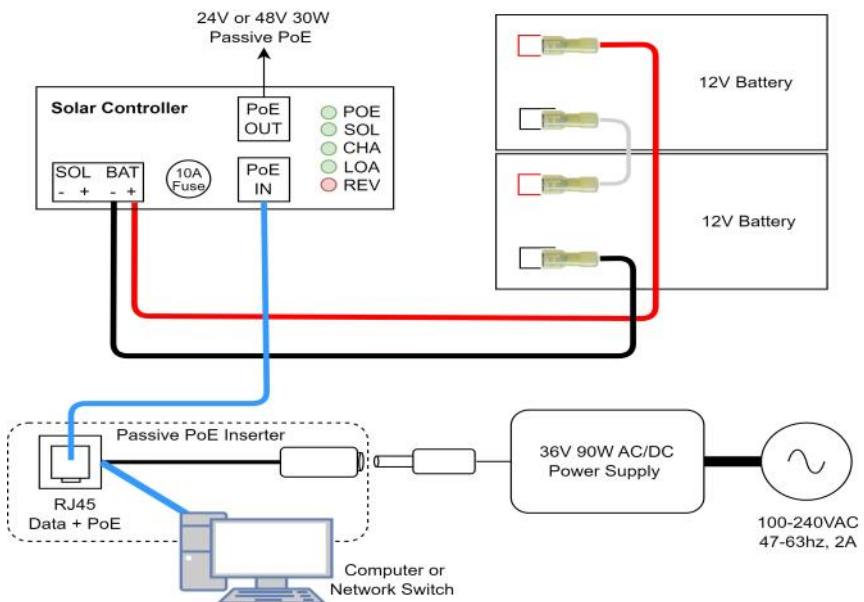

24V Battery Configuration

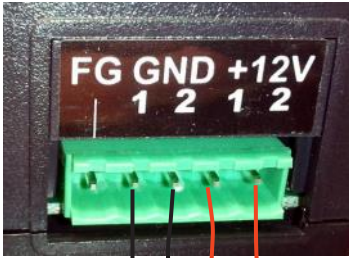

FG = Frame Ground (Do Not Connect to V-)

GND = V- (There are two V- connections: 1 and 2)

+12V or +24V = V+ (There are two V+ connections: 1 and 2)

Device 2

Device 1

Wire Terminal Connector Pinout

TECH CORNER

- 1. CONTROLLER:** The 12V controller turns off power to the load at 11V and reconnects when the battery reaches 12V. The 24V controller turns off at 20V and on at 24V. This protects the batteries from overdischarge and increases battery life and performance.
- 2. CAPACITY:** The UPSPro[®] with 2 AGM battery provides 216Wh of backup power and will keep a 25W load alive for ~4.5hrs. If load is less, then backup time is longer.
- 3. BATTERY MAINTENANCE:** The batteries used in the UPSPro[®] systems don't require any maintenance. AGM should last up to 5 years in normal use. **Note: Never store batteries for any length of time in a discharged state or it will damage the battery.**
- 4. BATTERY OVERDISCHARGE:** We highly recommend hooking all equipment loads to the controller load outputs. These outputs will disconnect the load if the battery voltage drops below 11V/20V and this will protect the battery from over-discharge. If batteries get completely discharged, you will reduce the battery life and you will need to supercharge them with a good quality 10A automotive battery charger. Don't charge for more than 8hrs on an automotive charger. Once they are back to a normal operating range, the integrated charge controller will maintain the charge.
- 5. POE OUTPUT:** The Passive PoE output is either 24V or 48V depending on the model you have selected. Be sure any device you are plugging into this output is compatible with the voltage or you might damage your device. Also, the port is 10/100Mb. It does not support Gigabit speeds.

6. TROUBLESHOOTING:

- A. *There is no Load Output?***—If battery voltage is too low, the charge controller will turn off the load outputs. On a 12V battery system the load will turn off if battery is <11V. On a 24V battery system the load will turn off at <20V. It won't turn back on until the battery voltage exceeds 12V/24V. Also check front panel fuse.
- B. *I want to add solar panels to extend the backup time. What is the largest solar panel I can use?*** Max Solar Panel Size = 12V 100W , 24V 200W
- C. *The CHA light is flashing. What does that mean?*** The CHA or Charge light flashes when the batteries are almost full and the controller switches to PWM float mode.
- D. *What is the REV light?*** The REV light means that the battery connections are backward. Please correct immediately to avoid damage to the controller.
- 6. ACCESSORIES:** Tycon[®] offers a variety of accessories to meet almost any need. Just visit tyconsystems.com for more info.

Limited Warranty

The UPSPro[®] products are supplied with a limited 36 month warranty which covers material and workmanship defects. This warranty does not cover the following:

- Parts requiring replacement due to improper installation, misuse, poor site conditions, faulty power, etc.
- Lightning or weather damage.
- Physical damage to the external & internal parts.
- Products that have been opened, altered, or defaced.
- Water damage for units that were not mounted according to user manual.
- Usage other than in accordance with instructions and the normal intended use.

NOTES

