



RPPL-LG PWM

RemotePro® Outdoor Solar Power System

- Wireless Base Stations and Client Devices
- Surveillance Cameras
- Mission Critical Backup Power
- Remote Sensors



Congratulations! on your purchase of the RemotePro® Outdoor Off-Grid solar power system. Please take a moment to review this Qwik Install Guide before assembly or battery installation.



DANGER! Avoid Powerlines! You Can Be Killed!

When following the instructions in this guide take extreme care to avoid contact with overhead power lines, lights and power circuits. Contact with power lines, lights or power circuits may be fatal. We recommend to install no closer than 20 feet to any power lines.

Safety: For your own protection, follow these safety rules.

- **Perform as many functions as possible on the ground**
- **Do not attempt to install on a rainy, windy or snowy day or if there is ice or snow accumulation at the install site or if the site is wet.**
- **Make sure there are no people, pets, etc. below when you are working on a roof or ladder.**



Recommended Tools: Phillips Screwdriver, Flat Blade Screwdriver, 5/16 nut driver



Please help preserve the environment and return used batteries to an authorized depot

Qwik Install

STEP 1: Prepare Enclosure - Attach Battery Brackets

Prepare the Velcro strap and the strap brackets, #5600066. Orient as shown.



Loosen 8 screws holding the mounting plate.

Slide the mounting plate towards you and lift up on the top end of the mounting plate while sliding the #5600066 brackets with Velcro Straps over the end of the mounting plate.

Place the brackets as shown (approx 1.75" from the enclosure walls) and attach to the mounting plate using Qty 4 #8 x 3/8 pan head self tapping screws.

Tighten the Qty 8 mounting plate attach screws.

Position the #5600067 Battery Support Brackets ~7" from the top of the enclosure.

Attach to the mounting plate using Qty 6 #8 x 3/8 pan head self tapping screw. Note: The farthest left and right screw holes won't be used.

Route the Velcro straps through the slot in the #5600067 brackets. We recommend not installing the batteries at this time because it makes the enclosure heavy and harder to handle. We suggest installing the batteries once the enclosure is already mounted to a pole or wall.

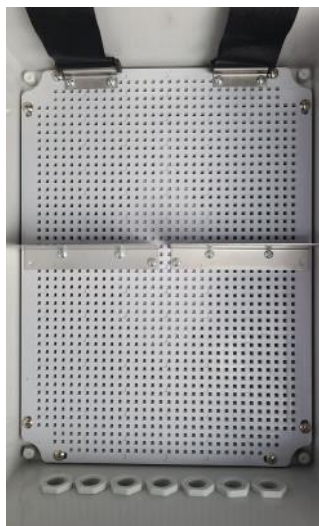

STEP 2: Prepare Enclosure - Attach Pole Mount Brackets

Caution: Pole mount brackets may have sharp edges, wear gloves.

Attach the pole mount brackets to the back of the enclosure using four flat washers as spacers under the bracket and four flat washers and self tapping screws on top of the bracket per the instructions that came with the enclosure.



STEP 3: Solar Battery Charge Controller Install

The system includes an advanced PWM charge controller with 20A load output. Mount the controller on the backplate using one or two #8 x 3/8" pan head self tapping screws. The mounting holes in the controller don't match exactly to the backplate holes. You can angle the controller to align two mounting holes. You can also mount the controller to the inside cover using velcro tape if you need more room on the backplate to mount your equipment.

The controller maintains proper charge parameters to extend battery life.

Attach the included battery cables to the controller BAT inputs. (Red to + and Black to -). Don't connect wires to battery until battery install step.

Note: The battery cable is different if 12V or 24V configuration. For 12V, all batteries are wired in parallel. If 24V, each pair of batteries is wired in series and both series pairs are wired in parallel.

The kit includes two Cable Gland Feedthroughs. Remove one or two hole plugs in the bottom of the enclosure and replace with one or two cable gland feedthroughs to be used to route external wires.

STEP 4: Solar Assembly

Assemble the solar mount bracket per the instructions that came with the solar mount and attach the solar panel with solar panel junction box toward the top or left/right side.



Set the bracket angle for your optimum winter angle ($\text{Latitude} * 0.9 + 30$ degrees)

Install the solar assembly to a 2" to 4" pole. Solar panel should be facing South if in Northern Hemisphere. Avoid any shading of solar panel.

STEP 5: Enclosure Mounting

Mount the enclosure to a pole using two stainless steel hose clamps. Cut off any extra hose clamp length after tightening to keep a clean install. As an option, the enclosure can also mount to a wall using the included 4 wall mount brackets and user supplied screws. It's best to mount the enclosure so it is shaded by the solar panel.

Route the solar cable through one of the feedthrough in the bottom of the enclosure and to the PWM solar controller solar panel inputs. Be careful to observe proper polarity. Red wire to + and Black wire to -. Don't plug the external solar connectors until the system startup step.

STEP 6: Battery Install

Insert the batteries by slipping under the Velcro straps. Attach all cables to the batteries and then tighten the straps.

Connect Battery wire negatives (Black) to battery terminal negatives (Black). Connect Battery wire positives (Red) to battery terminal positives (Red).

The Velcro straps will be on top of the connectors. This is the normal configuration.

STEP 7: System Startup

Once the battery is connected the solar controller display should turn on.

Plug in the external MC-4 solar connectors. Connect negative (-) connector first.

STEP 8: Finalize the Install

Make sure the lid gasket is clean and free from any particles, then close and latch the cover, making sure that wires are clear of the gasket area. There is a small combination lock included if you want to prevent someone from opening the enclosure without your knowledge.

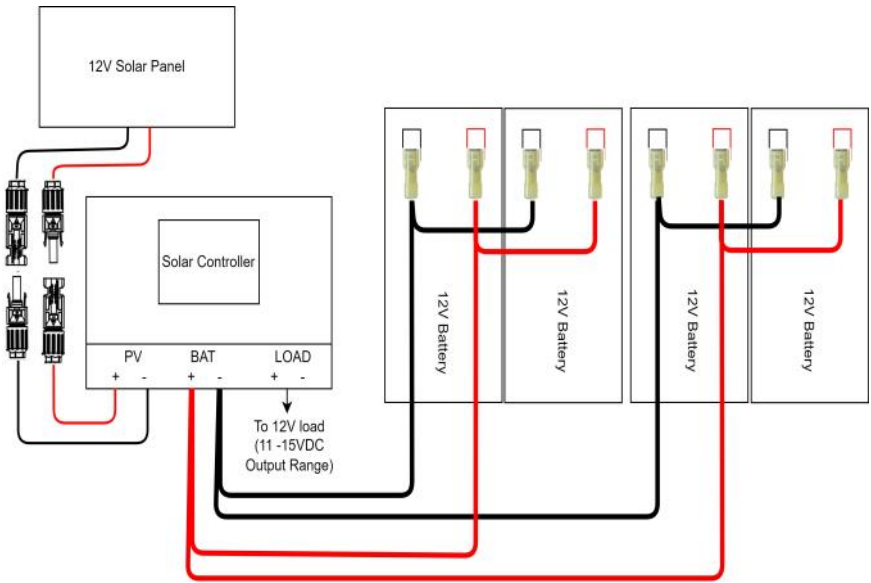

12V Battery Configuration

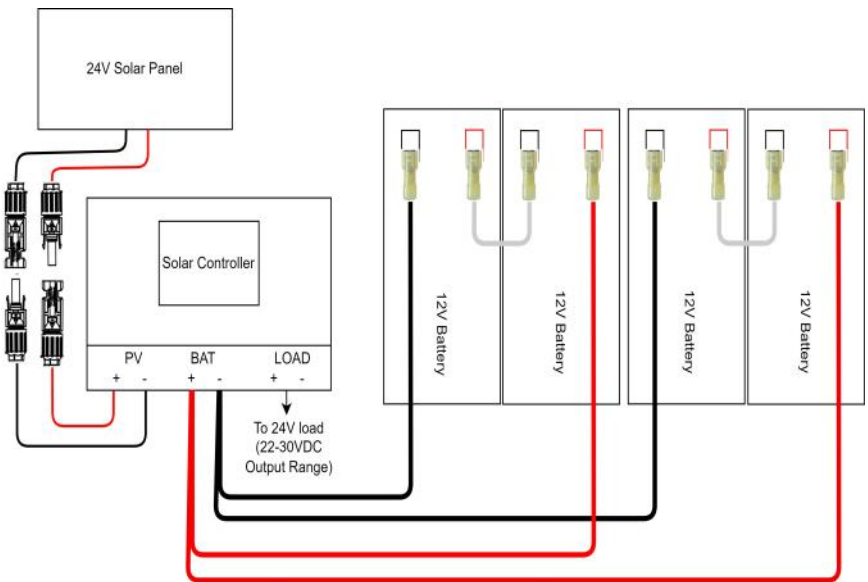

24V Battery Configuration

SPECIFICATION SUMMARY

Subject to change without notice

Lead Acid Battery Model #	Continuous Power Generation*	Reserve Time	Battery Voltage	AGM Battery Capacity	Solar Size
RPPL12-36-35	7.5W	28hrs	12V	36Ah	35W
RPPL24-36-30	6.5W	33hrs	24V	36Ah	30W

Lithium Battery Model #	Continuous Power Generation*	Reserve Time	Battery Voltage	Battery Capacity	Solar Size
RPPL12-40L-35	7.5W	48hrs	12V	40Ah	35W
RPPL12-40L-85	15W	24hrs	12V	40Ah	85W
RPPL24-40L-30	6.5W	55hrs	24V	40Ah	30W

TECH CORNER

- 1. CONTROLLER:** In 12V mode, the controller turns off power to the load at 11V and reconnects when the battery reaches 12V. In 24V mode, the controller turns off at 20V and on at 24V. This protects the batteries from overdischarge and increases battery life and performance.
- 2. CAPACITY:** The RemotePro® with 4 AGM battery provides 432Wh of backup power.
- 3. BATTERY MAINTENANCE:** The batteries used in the RemotePro® systems don't require any maintenance. AGM should last up to 5 years in normal use. **Note: Never store batteries for any length of time in a discharged state or it will damage the battery.**
- 4. BATTERY OVERDISCHARGE:** We highly recommend hooking all

equipment loads to the controller load outputs. These outputs will disconnect the load if the battery voltage drops below 11V/20V and this will protect the battery from over-discharge. If batteries get completely discharged, you will reduce the battery life and you will need to super-charge them with a good quality 10A automotive battery charger. Don't charge for more than 8hrs on an automotive charger. Once they are back to a normal operating range, the integrated charge controller will maintain the charge.

5. TROUBLESHOOTING:

- A. *There is no Load Output?***— The load output is turned off by the button on the controller -or- If battery voltage is too low, the charge controller will turn off the load outputs. On a 12V battery system the load will turn off if battery is <11V. On a 24V battery system the load will turn off at <20V. It won't turn back on until the battery voltage exceeds 12V/24V.
- B. *I want to add additional solar panels. What is the largest solar panel I can use?*** Max Solar Panel Size = 12V battery: 200W , 24V battery: 400W
- C. *The voltage shown on the controller is 12V but my batteries are wired for 24V?*** The PWM controller ships in Auto voltage configuration. It will automatically detect the correct voltage. If the batteries are wired for 24V but the battery voltage is too low, the controller may think the connected battery is 12V. In this case, refer to the controller manual and set the controller for 24V battery instead of Auto.

6. **ACCESSORIES:** Tycon[®] offers a variety of accessories to meet almost any need. Just visit tyconsystems.com for more info.

Limited Warranty

The RemotePro[®] products are supplied with a limited 36 month warranty which covers material and workmanship defects. This warranty does not cover the following:

- Parts requiring replacement due to improper installation, misuse, poor site conditions, faulty power, etc.
- Lightning or weather damage.
- Physical damage to the external & internal parts.
- Products that have been opened, altered, or defaced.
- Water damage for units that were not mounted according to user manual.
- Usage other than in accordance with instructions and the normal intended use.

NOTES

