



RPPL-LG SCPOE

RemotePro[®] Outdoor Solar Power System

- Wireless Base Stations and Client Devices
- Surveillance Cameras
- Mission Critical Backup Power
- Remote Sensors



Congratulations! on your purchase of the RemotePro[®] Outdoor Off-Grid solar power system. Please take a moment to review this Qwik Install Guide before assembly or battery installation.



DANGER! Avoid Powerlines! You Can Be Killed!

When following the instructions in this guide take extreme care to avoid contact with overhead power lines, lights and power circuits. Contact with power lines, lights or power circuits may be fatal. We recommend to install no closer than 20 feet to any power lines.

Safety: For your own protection, follow these safety rules.

- **Perform as many functions as possible on the ground**
- **Do not attempt to install on a rainy, windy or snowy day or if there is ice or snow accumulation at the install site or if the site is wet.**
- **Make sure there are no people, pets, etc. below when you are working on a roof or ladder.**



Recommended Tools: Phillips Screwdriver, Flat Blade Screwdriver, 5/16 nut driver



Please help preserve the environment and return used batteries to an authorized depot

Qwik Install

STEP 1: Prepare Enclosure - Attach Battery Brackets

Prepare the Velcro strap and the strap brackets, #5600066. Orient as shown.



Loosen 8 screws holding the mounting plate.

Slide the mounting plate towards you and lift up on the top end of the mounting plate while sliding the #5600066 brackets with Velcro Straps over the end of the mounting plate.

Place the brackets as shown (approx 1.75" from the enclosure walls) and attach to the mounting plate using Qty 4 #8 x 3/8 pan head self tapping screws.

Tighten the Qty 8 mounting plate attach screws.

Position the #5600067 Battery Support Brackets ~7" from the top of the enclosure.

Attach to the mounting plate using Qty 6 #8 x 3/8 pan head self tapping screw. Note: The farthest left and right screw holes won't be used.

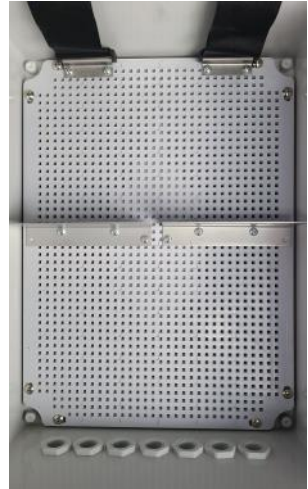

Route the Velcro straps through the slot in the #5600067 brackets. We recommend not installing the batteries at this time because it makes the enclosure heavy and harder to handle. We suggest installing the batteries once the enclosure is already mounted to a pole or wall.

STEP 2: Prepare Enclosure - Attach Pole Mount Brackets

Caution: Pole mount brackets may have sharp edges, wear gloves.

Attach the pole mount brackets to the back of the enclosure using four flat washers as spacers under the bracket and four flat washers and self tapping screws on top of the bracket per the instructions that came with the enclosure.



STEP 3: Solar Battery

Charge Controller Install

The system includes an advanced PWM charge controller with PoE output (SCPOE). Mount the controller on the backplate using one or two #8 x 3/8" pan head self tapping screws. The mounting holes in the controller don't match exactly to the backplate holes. You can angle the controller to align two mounting holes. You can also mount the controller to the inside cover using velcro tape if you need more room on the backplate to mount your equipment.



The controller maintains proper charge parameters to extend battery life.

Remove the green connector on the front of the unit and don't install again until system startup phase. Attach the included battery cables to the controller BAT inputs on the green connector. (Red to + and Black to -). Don't connect wires to battery until battery install step.

Note: The battery cable is different if 12V or 24V configuration. For 12V, all batteries are wired in parallel. If 24V, each pair of batteries is wired in series and both series pairs are wired in parallel.

The controller has an RJ45 Passive PoE Output (24V or 48V) and there is also a green wire terminal output on the back of the controller which will be equal to the battery voltage and is also controlled by the Low Voltage Disconnect function of the controller. Wire Terminal output supports 1.5A max.

The kit includes two Cable Gland Feedthroughs. Remove one or two hole plugs in the bottom of the enclosure and replace with one or two cable gland feedthroughs to be used to route external wires.

STEP 4: Solar Assembly

Assemble the solar mount bracket per the instructions that came with the solar mount and attach the solar panel with solar panel junction box toward the top or left/right side.

Set the bracket angle for your optimum winter angle (Latitude * 0.9 + 30 degrees)



Install the solar assembly to a 2" to 4" pole. Solar panel should be facing South if in Northern Hemisphere. Avoid any shading of solar panel.

STEP 5: Enclosure Mounting

Mount the enclosure to a pole using two stainless steel hose clamps. Cut off any extra hose clamp length after tightening to keep a clean install. As an option, the enclosure can also mount to a wall using the included 4 wall mount brackets and user supplied screws. It's best to mount the enclosure so it is shaded by the solar panel.

Connect the solar cable through one of the feedthrough in the bottom of the enclosure and to the SCPOE solar controller front green connector. Be careful to observe proper polarity. Red wire to + and Black wire to -. Don't plug the external solar connectors until the system startup step.

STEP 6: Battery Install

Insert the batteries by slipping under the Velcro straps. Attach all cables to the batteries and then tighten the straps.

Connect Battery wire negatives (Black) to battery terminal negatives (Black). Connect Battery wire positives (Red) to battery terminal positives (Red).

The Velcro straps will be on top of the connectors. This is the normal configuration.

STEP 7: System Startup

Double check wiring of the green connector. Solar cable to SOL +/- and Battery Cables to BAT +/- . Note: there are two BAT- connections. You can use either or both.

Plug the green connector to the controller. If battery voltage is >12V (SCPOE-12xx) or >24V (SCPOE-24xx) the controller should be powered up.

Plug the external MC-4 connectors to the mating connectors from the solar panel. Connect negative (-) first.

You should see the SOL, CHA and LOA lights lit on the controller.

SOL means that there is Solar Power coming from the solar panel.

CHA means the battery is charging.

LOA means the load output is ON. POE OUT is on, wire terminal is ON.

STEP 8: Finalize the Install

Make sure the lid gasket is clean and free from any particles, then close and latch the cover, making sure that wires are clear of the gasket area. There is a small combination lock included if you want to prevent someone from opening the enclosure without your knowledge.

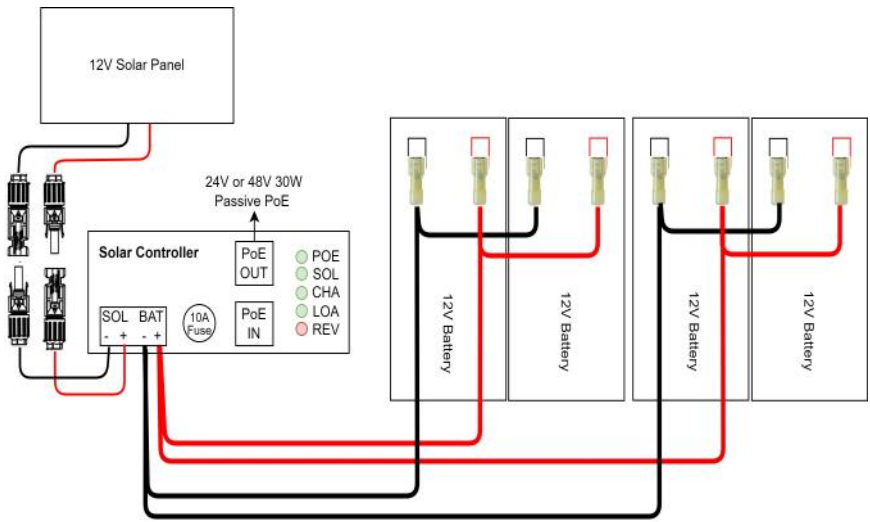

12V Battery Configuration

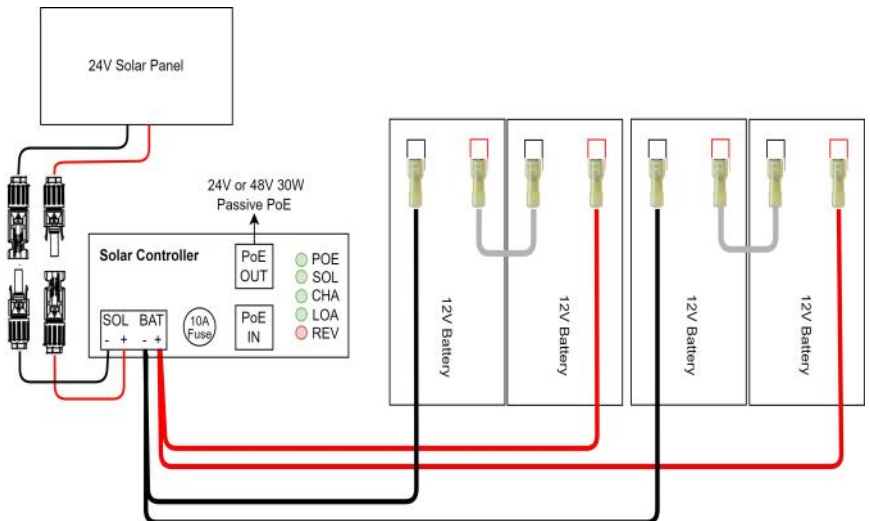

24V Battery Configuration

SPECIFICATION SUMMARY

Subject to change without notice

Lead Acid Battery Model #	Continuous Power Generation*	Reserve Time	Battery Voltage	POE Out	AGM Battery Capacity	Solar Size
RPPL1224-36-35	7.5W	28hrs	12V	24V	36Ah	35W
RPPL1248-36-35	7.5W	28hrs	12V	48V	36Ah	35W
RPPL1224-36-85	9W	24hrs	12V	24V	36Ah	85W
RPPL1248-36-85	9W	24hrs	12V	48V	36Ah	85W
RPPL2424-36-30	6.5W	33hrs	24V	24V	36Ah	30W
RPPL2448-36-30	6.5W	33hrs	24V	48V	36Ah	30W

Lithium Battery Model #	Continuous Power Generation*	Reserve Time	Battery Voltage	POE Out	Battery Capacity	Solar Size
RPPL1224-40L-35	7.5W	48hrs	12V	24V	40Ah	35W
RPPL1248-40L-35	7.5W	48hrs	12V	48V	40Ah	35W
RPPL1224-40L-85	15W	24hrs	12V	24V	40Ah	85W
RPPL1248-40L-85	15W	24hrs	12V	48V	40Ah	85W
RPPL2424-40L-30	6.5W	55hrs	24V	24V	40Ah	30W
RPPL2448-40L-30	6.5W	55hrs	24V	48V	40Ah	30W

TECH CORNER

1. **CONTROLLER:** The 12V controller turns off power to the load at 11V and reconnects when the battery reaches 12V. The 24V controller turns off at 20V and on at 24V. This protects the batteries from overdis-

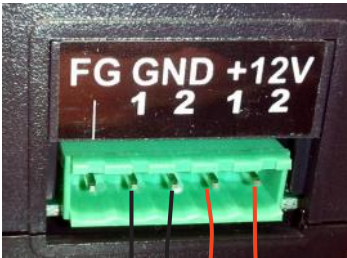

FG = Frame Ground (Do Not Connect to V-)

GND = V- (There are two V- connections: 1 and 2)

+12V or +24V = V+ (There are two V+ connections: 1 and 2)

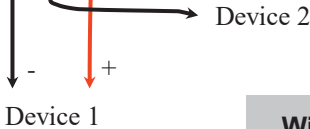

Wire Terminal Connector Pinout

charge and increases battery life and performance.

2. **CAPACITY:** The RemotePro[®] with 4 AGM battery provides 432Wh of backup power.

3. **BATTERY MAINTENANCE:** The batteries used in the RemotePro[®] systems don't require any maintenance. AGM should last up to 5 years in normal use. **Note: Never store batteries for any length of time in a discharged state or it will damage the battery.**

4. **BATTERY OVERDISCHARGE:** We highly recommend hooking all equipment loads to the controller load outputs. These outputs will disconnect the load if the battery voltage drops below 11V/20V and this will protect the battery from over-discharge. If batteries get completely discharged, you will reduce the battery life and you will need to super-charge them with a good quality 10A automotive battery charger. Don't charge for more than 8hrs on an automotive charger. Once they are back to a normal operating range, the integrated charge controller will maintain the charge.

5. **POE OUTPUT:** The Passive PoE output is either 24V or 48V depending on the model you have selected. Be sure any device you are plugging into this output is compatible with the voltage or you might damage your device. Also, the port is 10/100Mb. It does not support Gigabit speeds.

6. TROUBLESHOOTING:

A. *There is no Load Output?*—If battery voltage is too low, the charge controller will turn off the load outputs. On a 12V battery system the load will turn off if battery is <11V. On a 24V battery system the load will turn off at <20V. It won't turn back on until the battery voltage exceeds 12V/24V. Also check front panel fuse.

- B. I want to add additional solar panels. What is the largest solar panel I can use?** Max Solar Panel Size = 12V 100W , 24V 200W
- C. The CHA light is flashing. What does that mean?** The CHA or Charge light flashes when the batteries are almost full and the controller switches to PWM float mode.
- D. What is the REV light?** The REV light means that the battery connections are backward. Please correct immediately to avoid damage to the controller.
- E. I hooked everything up but the controller won't power up?**
The most common issue is the SCPOE controller is a 24V model but you connected the batteries in 12V configuration or the SCPOE is a 12V model and you hooked up the batteries in 24V configuration. Confirm the battery voltage is compatible with the model of SCPOE solar controller. (SCPOE-12 or SCPOE-24)
6. **ACCESSORIES:** Tycon[®] offers a variety of accessories to meet almost any need. Just visit tyconsystems.com for more info.

Limited Warranty

The RemotePro[®] products are supplied with a limited 36 month warranty which covers material and workmanship defects. This warranty does not cover the following:

- Parts requiring replacement due to improper installation, misuse, poor site conditions, faulty power, etc.
- Lightning or weather damage.
- Physical damage to the external & internal parts.
- Products that have been opened, altered, or defaced.
- Water damage for units that were not mounted according to user manual.
- Usage other than in accordance with instructions and the normal intended use.

NOTES