



UPS-PL-120 LG

UPSPro[®] Backup Power System

- Wireless Base Stations and Client Devices
- Surveillance Cameras
- Sensor Applications
- Lighting Applications
- Electronic Gates



Congratulations! on your purchase of the UPSPro[®] backup power system. Please take a moment to review this Qwik Install Guide before assembly or battery installation.



DANGER! Avoid Powerlines! You Can Be Killed!

When following the instructions in this guide take extreme care to avoid contact with overhead power lines, lights and power circuits. Contact with power lines, lights or power circuits may be fatal. We recommend to install no closer than 20 feet to any power lines.

Safety: For your own protection, follow these safety rules.

- **Perform as many functions as possible on the ground**
- **Do not attempt to install on a rainy, windy or snowy day or if there is ice or snow accumulation at the install site or if the site is wet.**
- **Make sure there are no people, pets, etc. below when you are working on a roof or ladder.**



Recommended Tools: Phillips Screwdriver, 5/16" nut driver, Flat Blade Screwdriver



Please help preserve the environment and return used batteries to an authorized depot

Qwik Install

STEP 1: Prepare Enclosure - Attach Battery Brackets

Prepare the Velcro strap and the strap brackets #5600066. Orient as shown.

Loosen 8 screws holding the mounting plate.

Slide the mounting plate towards you and lift up on the top end of the mounting plate while sliding the #5600066 brackets with Velcro Straps over the end of the mounting plate.

Place the brackets as shown (approx 1.75" from the enclosure walls) and attach to the mounting plate using Qty 4 #8 x 3/8 pan head self tapping screws.

Tighten the Qty 8 mounting plate attach screws.

Position the #5600067 Battery Support Brackets ~7" from the top of the enclosure.

Attach to the mounting plate using Qty 6 #8 x 3/8 pan head self tapping screw. Note: The farthest left and right screw holes won't be used.

Route the Velcro straps through the slot in the #5600067 brackets. We recommend not installing the batteries at this time because it makes the enclosure heavy and harder to handle. We suggest installing the batteries once the enclosure is already mounted to a pole.

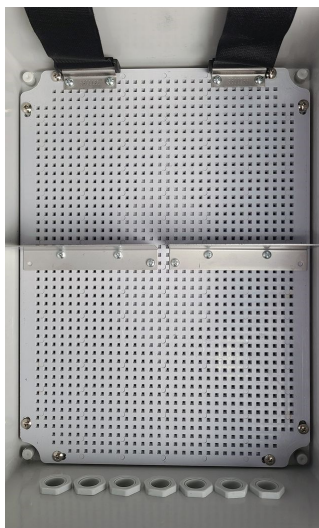

STEP 2: Prepare Enclosure - Attach Pole Mount Brackets

Caution: Pole mount brackets may have sharp edges, wear gloves.

Attach the pole mount brackets to the back of the enclosure using four flat washers as spacers under the bracket and four flat washers and self tapping screws on top of the bracket per the instructions that came with the enclosure.

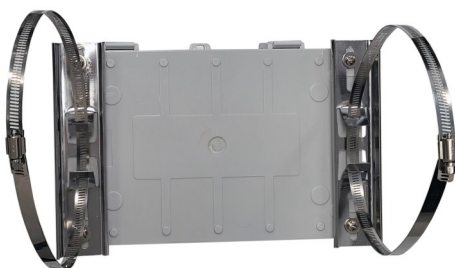

STEP 3: Solar Battery Charge Controller Install

The system includes an advanced PWM charge controller with LCD display. The controller mounts on the backplate using two or four #8 x 3/8" pan head self tapping screws. This controller maintains proper charge parameters over temperature to extend battery life and enables the system to be Solar Ready™. Solar panels can be added at any time to extend backup time or provide a backup power source to keep the batteries fully charged.

The kit includes two Cable Gland Feedthroughs. Remove one or two hole plugs in the bottom of the enclosure and replace with one or two cable gland feedthroughs to be used to route external wires.



Attach the included battery cable to the controller BAT inputs. (Red to + and Black to -).

Note: The battery cable is different if 12V or 24V configuration. For 12V all batteries are wired in parallel. If 24V, each pair of batteries is wired in series and both series pairs are wired in parallel.

Connect the bare wires of the short cable that came with the Battery Charger to the **BAT** inputs of the Controller in parallel with the battery cables. Be sure to maintain polarity. Black wire to BAT-.

Connect the wires for any equipment, that will be powered by the system, to the controller load output.

Mount the controller inside the enclosure with included screws.

STEP 4: Battery Charger Install

The battery charger is an AC input battery charging power source. The output voltage of the battery charger must match the battery voltage, either 12V or 24V.

Be very careful. Never work with live circuits. Consult a licensed electrician for AC connection.

The AC input of the battery charger is an attached AC power cord. The plug can be cut off, if desired, to connect to an AC input wire directly,

12V Battery Configuration

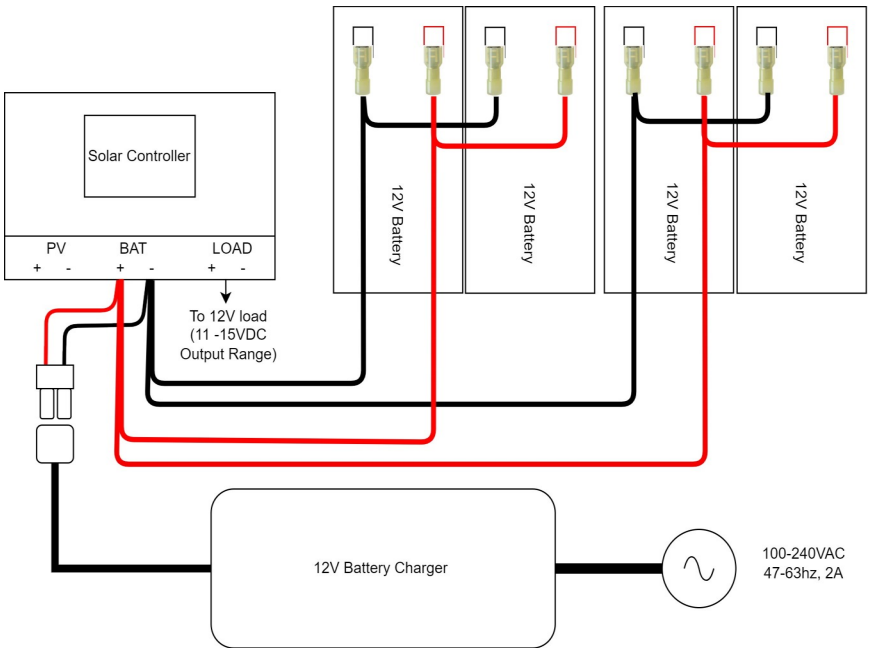

24V Battery Configuration

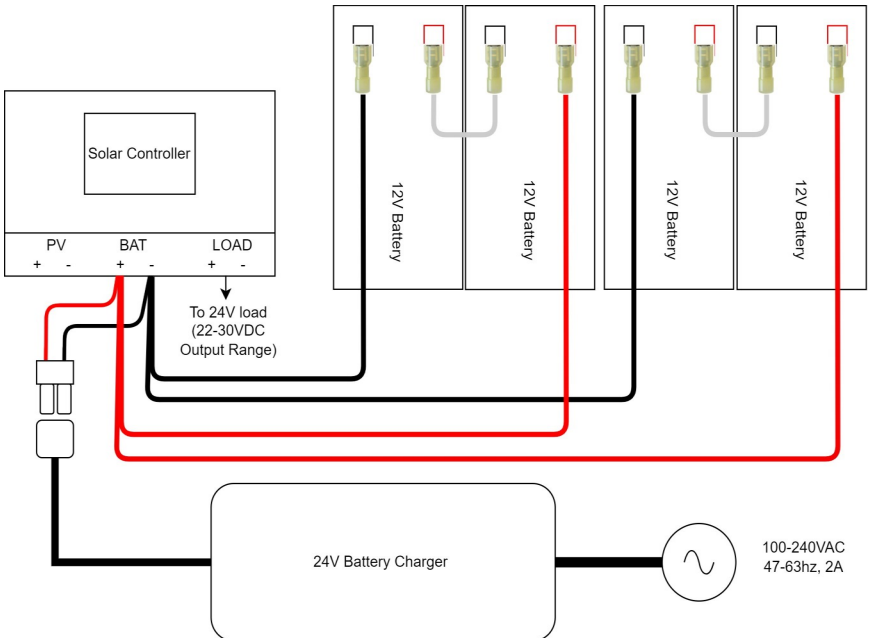

using wire nuts. **Cutting off the plug will not void the warranty.** Another option is to attach a compact female AC outlet to an AC power cable routed into the bottom of the enclosure.

The battery charger can sit loosely in the bottom of the enclosure or can be strapped on top of the batteries, using the battery strap.

STEP 5: Enclosure Mounting

Mount the enclosure to a pole using two stainless steel hose clamps. Cut off any extra hose clamp length after tightening to keep a clean install.

As an option, the enclosure can also mount to a wall using the included 4 wall mount brackets and user supplied screws.

STEP 6: Battery Install

Insert the batteries by slipping under the Velcro straps and then tightening the straps. The Velcro straps will be on top of the connectors. This is the normal configuration.

STEP 7: System Startup

Connect Battery wire negatives (Black) to battery terminal negative (Black). Connect Battery wire positives (Red) to battery terminal positive (Red). The Solar charge controller will power up.

After the controller is connected to the battery, you can connect the Battery Charger output connector. The connectors are keyed to prevent reverse polarity.

Refer to the documentation that came with the controllers for operation of the controllers.

If battery voltage is >12V your connected equipment should be powered up. Press the Load button (lightbulb icon) to turn load on/off.

STEP 8: Make sure the lid gasket is clean and free from any particles, then close and latch the cover, making sure that wires are clear of the gasket area. There is a small combination lock included if you want to prevent someone from opening the enclosure without you knowing.

TECH CORNER

Additional Information you may find useful

- 1. CONTROLLER:** The 12V controller turns off power to the load at 11V and reconnects when the battery reaches 12V. The 24V controller turns off at 20V and on at 24V. This protects battery from overdischarge and increases battery life and performance.
- 2. CAPACITY:** The UPSPro[®] with 4 AGM battery provides 432Wh of

SPECIFICATION SUMMARY

Subject to change without notice

AGM Battery Model #	Battery Voltage	Battery Capacity	Total Watt Hours Storage Capacity	Backup Time at 25W Avg Load
UPS-PL12-36-120	12VDC	36Ah	432	9hrs
UPS-PL24-36-120	24VDC	36Ah	432	9hrs

Lithium Battery Model #	Battery Voltage	Battery Capacity	Total Watt Hours Storage Capacity	Backup Time at 25W Avg Load
UPS-PL12-40L-120	12VDC	40Ah	480	15hrs
UPS-PL24-40L-120	24VDC	40Ah	480	15hrs

backup power and will keep a 25W load alive for ~9hrs. If load is less, then backup time is longer. Backup time is doubled using Lithium Batteries.

3. **BATTERY MAINTENANCE:** The batteries used in the UPSPro® systems don't require any maintenance. AGM should last up to 5 years and Lithium up to 10 years in normal use. **Note: Never store batteries for any length of time in a discharged state or it will damage the battery.**

4. **BATTERY OVERDISCHARGE:** We highly recommend hooking all equipment loads to the controller load output. This output will disconnect the load if the battery voltage drops below 11V/20V and this will protect the battery from over-discharge. If batteries get completely discharged, you will reduce the battery life and you will need to super-charge them with a good quality 10A automotive battery charger. Don't charge for more than 8hrs on an automotive charger. Once they are back to a normal operating range, the integrated charge controller will maintain the charge.

5. TROUBLESHOOTING:

- A. ***There is no Load Output?***—If battery voltage is too low, the charge controller will turn off the load outputs. On a 12V battery system the load will turn off if battery is <11V. On a 24V battery system the load will turn off at <20V. It won't turn back on until the battery voltage exceeds 12V/24V.
- B. ***The fan in my Battery Charger keeps turning on and off?***- This is normal. The fan is thermostatically controlled and will turn on automatically when the charger circuitry gets too hot.

C. I want to add solar panels to extend the backup time. What is the largest solar panel I can use? Max Solar Panel Size 12V 240W , 24V 480W

6. **ACCESSORIES:** Tycon[®] offers a variety of accessories to meet almost any need. Just visit tyconsystems.com for more info.

Limited Warranty

The UPSPro[®] products are supplied with a limited 36 month warranty which covers material and workmanship defects. This warranty does not cover the following:

- Parts requiring replacement due to improper installation, misuse, poor site conditions, faulty power, etc.
- Lightning or weather damage.
- Physical damage to the external & internal parts.
- Products that have been opened, altered, or defaced.
- Water damage for units that were not mounted according to user manual.
- Usage other than in accordance with instructions and the normal intended use.

NOTES

