



# **RPPL-SM**

## **RemotePro<sup>®</sup>**

### **Remote Power System**

- Wireless Base Stations and Client Devices
- Surveillance Cameras
- Remote Sensors
- Remote Lighting
- Off Grid Electronics



**Congratulations!** on your purchase of the RemotePro<sup>®</sup> off-grid remote power system. Please take a moment to review this Qwik Install Guide before assembly or battery installation.



### **DANGER! Avoid Powerlines!**

#### **You Can Be Killed!**

When following the instructions in this guide take extreme care to avoid contact with overhead power lines, lights and power circuits. Contact with power lines, lights or power circuits may be fatal. We recommend to install no closer than 20 feet to any power lines.

**Safety:** For your own protection, follow these safety rules.

- **Perform as many functions as possible on the ground**
- **Do not attempt to install on a rainy, windy or snowy day or if there is ice or snow accumulation at the install site or if the site is wet.**
- **Make sure there are no people, pets, etc. below when you are working on a roof or ladder.**



**Recommended Tools:** Phillips Screwdriver, 1/2" Open End Wrench, 5/16" nut driver, Flat Blade Screwdriver



**Please help preserve the environment and return used batteries to an authorized depot**

# Qwik Install

## STEP 1: Prepare Enclosure - Attach Battery Brackets

Prepare the Velcro strap and the strap bracket #5600066. Orient as shown.



Loosen 8 screws holding the mounting plate.

Slide the mounting plate towards you and lift up on the top end of the mounting plate while sliding the #5600066 bracket with Velcro Strap over the end of the mounting plate.

Center the bracket and attach to the mounting plate using Qty 2 #8 x 3/8 pan head self tapping screw.

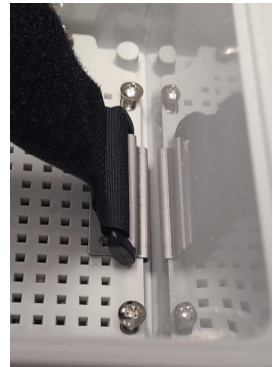

Tighten the Qty 8 mounting plate attach screws.

Position the #5600067 Battery Support Bracket. If one battery, then ~3 3/4" from the top of the housing. (~6 1/2" if two batteries)

Center the bracket and attach to the mounting plate using Qty 4 #8 x 3/8 pan head self tapping screw.



Route the Velcro strap through the slot in the #5600067 bracket. We recommend not installing the batteries at this time because it makes the enclosure heavy and harder to handle. We suggest installing the batteries once the enclosure is already mounted to a pole.

## STEP 2: Prepare Enclosure - Attach Pole Mount Brackets

**Caution:** Pole mount brackets may have sharp edges, wear gloves.

Attach the pole mount brackets to the back of the enclosure using four flat washers as spacers under the bracket and four flat washers and self tapping screws on top of the bracket per the instructions that came with the enclosure.

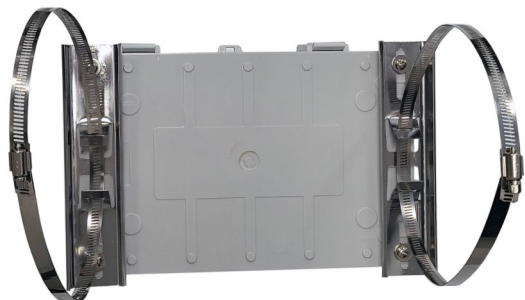

### STEP 3: Solar Assembly

Assemble the solar mount bracket per the instructions that came with the solar mount and attach the solar panel with solar panel junction box toward the top or left/right side.

Set the bracket angle for your optimum winter angle ( $\text{Latitude} * 0.9 + 30$  degrees)

Install the solar assembly to a 2" to 4" pole. Solar panel should be facing South if in Northern Hemisphere.



### STEP 4: Enclosure Mounting

Mount the enclosure to the pole beneath the solar panel using two stainless steel hose clamps. Be sure to leave enough room so that the enclosure door can open freely.

Mounting the enclosure so that it is shaded by the panel will help reduce the maximum temperature inside the box during the hottest part of the day.

Cut off any extra hose clamp length after tightening to keep a clean install.

### STEP 4: Solar Controller Install

The systems come with two different solar controllers depending on the model that was ordered. The smaller controller mounts on the backplate using two or four #8 x 3/8" pan head self tapping screws. The larger SCPOE controller mounts to the inside of the door using the included Velcro tape.

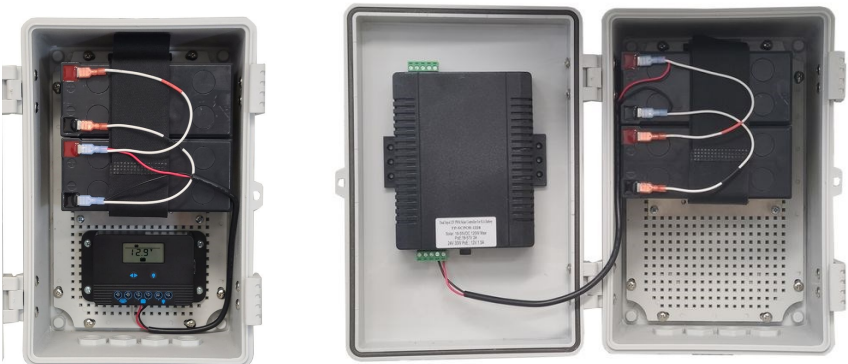

The kit includes two Cable Gland Feedthroughs. Remove one or two hole plugs in the bottom of the enclosure and replace with one or two cable gland feedthroughs to be used to route wires.

Route the included solar panel cable through one of the feedthrough and attach to the controller SOL inputs. (Red to + and Black to -).

Attach the included battery cable to the controller BAT inputs. (Red to + and Black to -).

**Note:** The battery cable is different if one or two batteries and if 12V or 24V configuration. If two batteries and 12V, the batteries are wired in parallel. If two batteries and 24V, the batteries are wired in series.

### 12V Configuration

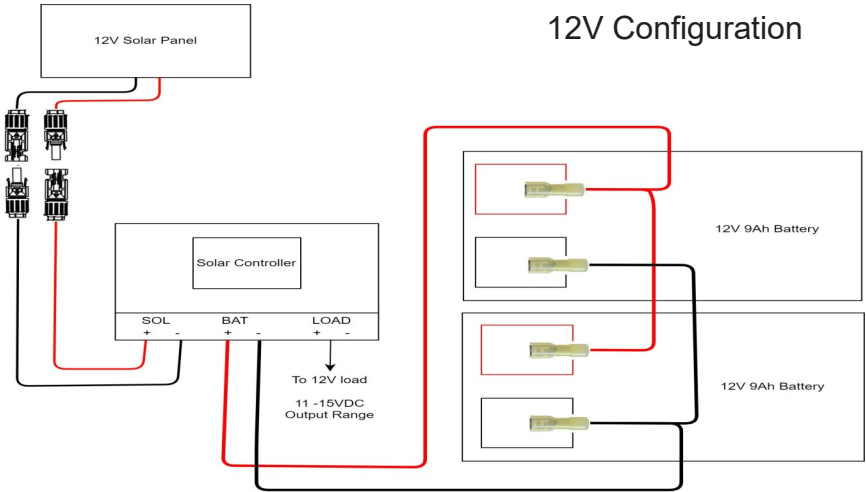

### 24V Configuration

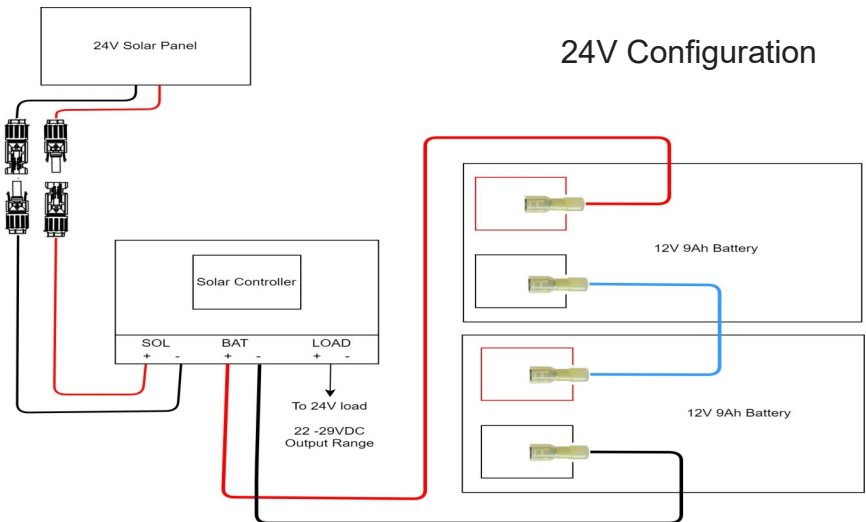

Connect the wires for any equipment, that will be powered by the system, to the controller load output on the small controller or Aux and/or PoE outputs on the large controller.

Mount the controller inside the enclosure with screws or Velcro tape, as required.

### STEP 5: Battery Install

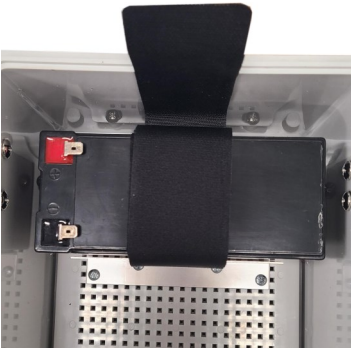

Insert the batteries by slipping under the Velcro strap and then tightening the strap.



Fold the end of the strap between the battery and the enclosure wall to allow access to the end of the Velcro strap for easy removal.

### STEP 6: System Startup

Connect any external equipment to the solar controller.

Connect Battery wire negative (Black) to battery terminal negative (Black). Connect Battery wire positive (Red) to battery terminal positive (Red). The Solar controller will power up.

**(Note:** Always connect battery before connecting solar. Disconnect solar before unplugging battery).

After the controller is connected to the battery, you can connect the solar. Push the MC4 solar connectors together until they are fully seated and snap into place. The connectors are keyed to prevent reverse polarity.

Check to make sure you see solar power indicators on the Solar Controller when the sun is hitting the panel. Refer to the documentation that came with the controllers for operation of the controllers.

If battery voltage is >12V your connected equipment should be powered up.

**STEP 7:** Make sure the lid gasket is clean and free from any particles, then close and latch the cover, making sure that wires are clear of the gasket area. There is a small combination lock included if you want to prevent someone from opening the enclosure without you knowing.

# SPECIFICATION SUMMARY

Subject to change without notice

Lead Acid Battery Model #	Continuous Power Generation*	Reserve Time	Battery Voltage	POE Out	AGM Battery Capacity	Solar Size
RPPL12-9-15	2.5W	21hrs	12V	--	9Ah	15W
RPPL12-18-15	3.2W	34hrs	12V	---	18Ah	15W
RPPL12-18-35	4.3W	25hrs	12V	---	18Ah	35W
RPPL24-18-30	4.3W	25hrs	24V	---	18Ah	30W
RPPL1224-18-15	3.2W	34hrs	12V	24V	18Ah	15W
RPPL1224-18-35	4.3W	25hrs	12V	24V	18Ah	35W
RPPL1248-18-15	3.2W	34hrs	12V	48V	18Ah	15W
RPPL1248-18-35	4.3W	25hrs	12V	48V	18Ah	35W

Lithium Battery Model #	Continuous Power Generation*	Reserve Time	Battery Voltage	POE Out	LiFePO4 Battery Capacity	Solar Size
RPPL12-10L-15	3.75W	24hrs	12V	--	10Ah	15W
RPPL12-10L-35	3.75W	24hrs	12V	---	10Ah	35W
RPPL12-20L-35	7.5W	24hrs	12V	--	20Ah	35W
RPPL1224-20L-35	7.5W	24hrs	12V	24V	20Ah	35W
RPPL1248-20L-35	7.5W	24hrs	12V	48V	20Ah	35W
RPPL24-20L-30	6.5W	27hrs	24V	—	20Ah	30W
RPPL2424-20L-30	6.5W	27hrs	24V	24V	20Ah	30W
RPPL2448-20L-30	6.5W	27hrs	24V	48V	20Ah	30W

# TECH CORNER

## *Additional Information you may find useful*

1. **CONTROLLER:** The 12V controller turns off power to the load at 11V and reconnects when the battery reaches 12V. The 24V controller turns off at 20V and on at 24V. This protects battery from overdischarge and increases battery life and performance.

2. **CAPACITY:** The RemotePro® RPPL-SM with 35W panel and 18Ah AGM battery is rated at 4.3W continuous power output with 3.5 hours of peak sun per day. Reserve battery capacity at 4.3W load is 25 hours. Lithium batteries nearly double this capacity.

3. **BATTERY MAINTENANCE:** The batteries used in the RemotePro® systems don't require any maintenance. The AGM should last up to 5 years in normal use while the Lithium should last 10 years. **Note: Never store batteries for any length of time in a discharged state or it will damage the battery.**

4. **BATTERY OVERDISCHARGE:** We highly recommend hooking all equipment loads to the controller voltage output. This output will disconnect the load if the battery voltage drops below 11V/20V and this will protect the battery from over-discharge. If batteries get completely discharged, you will reduce the battery life and you will need to supercharge them with a good quality 10A automotive battery charger. Don't charge for more than 8hrs on an automotive charger. Once they are back to a normal operating range, the integrated charge controller will maintain the charge.

### **8. TROUBLESHOOTING:**

A. **There is no Load Output?**—If battery voltage is too low, the charge controller will turn off the load outputs. On a 12V battery system the load will turn off if battery is <11V. On a 24V battery system the load will turn off at <20V. It won't turn back on until the battery voltage exceeds 12V/24V.

B. **Why is my solar panel voltage so high?**- Open circuit voltage on a 12V panel is around 23V, and about 40V on a 24V panel. Once you connect to the charge controller the panel voltage will be reduced to a little higher than the battery voltage.

C. **My system turns off at night and comes back on in the morning?**- This is a sure sign that the solar panels and/or battery capacity can't support the load. You should measure your actual load and recalculate to make sure you have adequate capacity.

9. **ACCESSORIES:** Tycon® offers a variety of accessories to meet almost any need. Just visit [tyconsystems.com](http://tyconsystems.com) for more info.

## **Limited Warranty**

The RemotePro<sup>®</sup> products are supplied with a limited 36 month warranty which covers material and workmanship defects. This warranty does not cover the following:

- Parts requiring replacement due to improper installation, misuse, poor site conditions, faulty power, etc.
- Lightning or weather damage.
- Physical damage to the external & internal parts.
- Products that have been opened, altered, or defaced.
- Water damage for units that were not mounted according to user manual.
- Usage other than in accordance with instructions and the normal intended use.

## **NOTES**