



UPS-120 Series

UPSPro[®]

Outdoor UPS System

- Wireless Base Stations and Client Devices
- Surveillance Cameras
- Mission Critical Backup Power
- Remote Sensors



Congratulations! on your purchase of the UPSPro[®] Outdoor UPS backup power system. Please take a moment to review this Qwik Install Guide before assembly or battery installation.



DANGER! Avoid Powerlines! You Can Be Killed!

When following the instructions in this guide take extreme care to avoid contact with overhead power lines, lights and power circuits. Contact with power lines, lights or power circuits may be fatal. We recommend to install no closer than 20 feet to any power lines.

Safety: For your own protection, follow these safety rules.

- **Perform as many functions as possible on the ground**
- **Do not attempt to install on a rainy, windy or snowy day or if there is ice or snow accumulation at the install site or if the site is wet.**
- **Make sure there are no people, pets, etc. below when you are working on a roof or ladder.**



Recommended Tools: Phillips Screwdriver, Flat Blade Screwdriver, 5/16" nut driver,



Please help preserve the environment and return used batteries to an authorized depot

Qwik Install

CAUTION: Be sure to connect the battery to the controller first and disconnect it last. Connecting solar panels to the controller without the battery connected could damage the controller.

Note: We strongly recommend installing the batteries and other equipment in the enclosure **after** mounting the enclosure to the pole or wall.

STEP 1: Attach top and bottom brackets to the enclosure.

STEP 2: Mount the enclosure to a pole using U-Bolts and/or 4 hose clamps. The enclosure can also be wall mounted using appropriate lag bolts (supplied by customer).

STEP 3: Attach the included DIN Rail to the door using hardware provided.

STEP 4: Install 4 cable feedthroughs to the bottom of the enclosure.

Note: There are multiple cable gland feedthrough in the bottom of the enclosure. If you are not using any of the feedthrough you can cut a short piece of wire, put it through the cable gland and tighten the cable gland on the wire to seal it.

STEP 5: Remove the fuse from the battery cable(s) and connect wires to the batteries, then install the batteries.

STEP 6: Install the PWM Solar Controller by attaching the green DIN Rail clips to the controller using screws provided. The extra parts aren't used. The controller can be mounted to the DIN rail on the door or one of the welded DIN Rails inside the enclosure. Connect the battery wires and the wires from the PowerVent™ fan to the controller battery input. Be sure to observe proper polarity. (RED=+).

CAUTION: Reverse polarity connections will damage the equipment.

STEP 7: Install the battery charger in the extra space inside the enclosure. It can sit on top of the batteries, next to the batteries or in front of

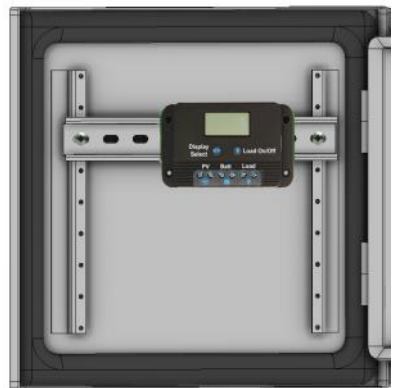
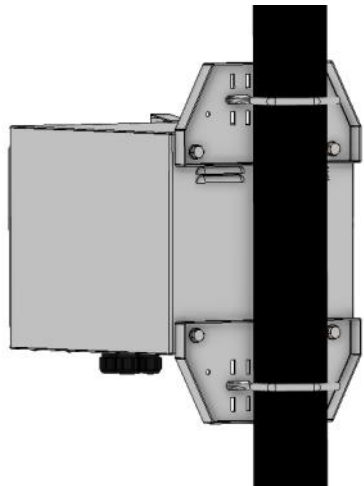

the batteries. Connect the output wires from the charger to the controller battery inputs. Be sure to observe proper polarity (RED = +).

STEP 8: Connect your load to the load output of the controller.

STEP 9: Double check wiring, then replace the fuse in the battery cables. The controller should power up and you should see parameters displayed on the display. The controller display shows battery voltage, charging current, load current and temperature. The load output should turn on automatically if the battery voltage is within the allowable range; you can also control the load output using the Load On/Off button.

STEP 10: Connect the charger power supply to a 120/240VAC source. Just cut off the connector, strip wires and use wire nuts to wire directly or plug into an existing outlet. When the charger is connected to an AC source you should see charging current to the battery on the controller display.

STEP 11: Make sure lid gasket is clean and free from any particles, then close the cover, making sure that wires are clear of the gasket and hinge area.

STEP 12: The UPSPro® is Solar Ready™ so a solar panel can be added at any time to provide supplemental or full time power. Solar panel will be connected to PV input (Solar Panel Symbol).

TECH CORNER

1. **CONTROLLER:** The controller turns off power to the load at 11V (22V if 24V array) and reconnects when the battery reaches 12.5V (25V if 24V array). This protects battery from over-discharge and increases battery life and performance.

2. **CAPACITY:** With a typical AP running 4W average. A single 12V 50Ah battery should be able to provide backup power for up to 75 hours at room temperature. For cold temperatures the capacity is reduced by 20-30%. Lithium batteries nearly double the backup time.

3. **VENTING:** The enclosure is vented thru the included PowerVent™. The fan is thermostatically controlled to turn on when the temperature inside the enclosure exceeds 45C. It runs on 12V to 24VDC.

4. **DUAL INPUTS:** The UPS-120 can be used with AC Power alone or Solar Power alone or a combination of both.

5. **SOLAR PANEL:** The controller used in the UPS-120 can handle a maximum panel size of 240W. Do not exceed 20A into the PV input of the solar controller.

6. **BATTERY MAINTENANCE:** The batteries used in the UPSPro® systems don't require any maintenance. They should last up to 5 years in normal use (10 years for Lithium). **Note: Never store batteries for**

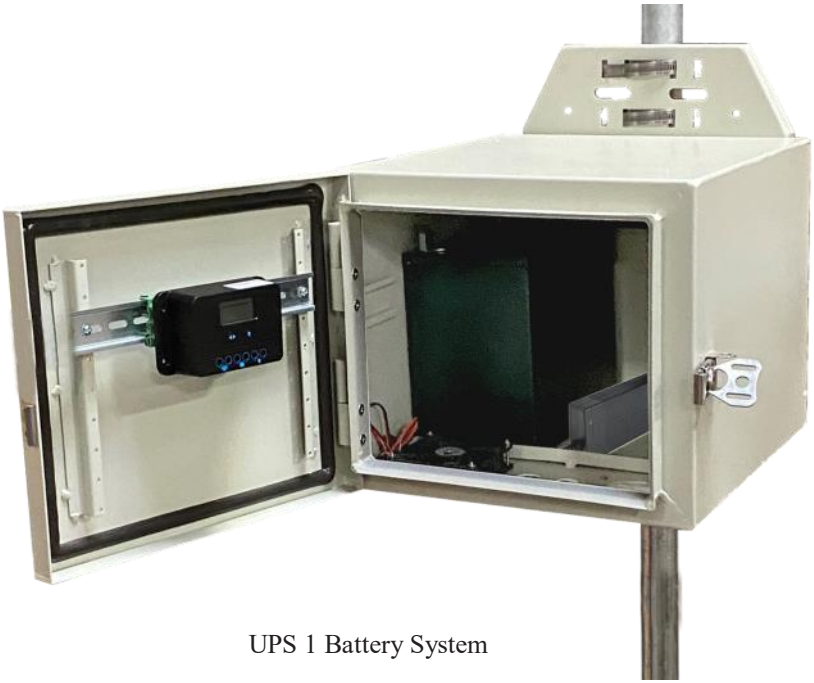

UPS 1 Battery System

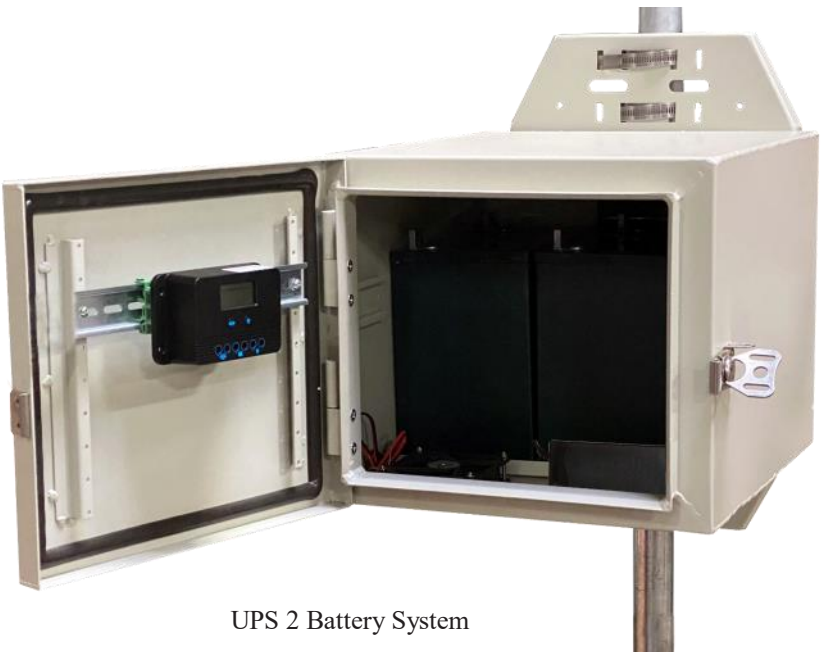

UPS 2 Battery System

any length of time in a discharged state or it will kill the battery, especially during cold weather.

7. BATTERY OVERDISCHARGE: We highly recommend hooking all equipment loads to the controller load output. This output will disconnect the load if the battery voltage is too low and this will protect the battery from over-discharge. If batteries get completely discharged because the equipment was connected directly to the battery, you will reduce the battery life.

8. LOAD OUTPUT: The LOAD output on the Solar Charge Controller is unregulated. What that means is the voltage output follows the battery voltage. This is typically 11-15V for a 12V system and 22-29V for a 24V system. It is up to the user to make sure the connected load is compatible with these voltages. A voltage regulator can be added to provide regulated output voltages. Tycon[®] offers a full range of DCDC converters and PoE Injectors with regulated outputs.



UPS-120 24V 2 Battery Configuration

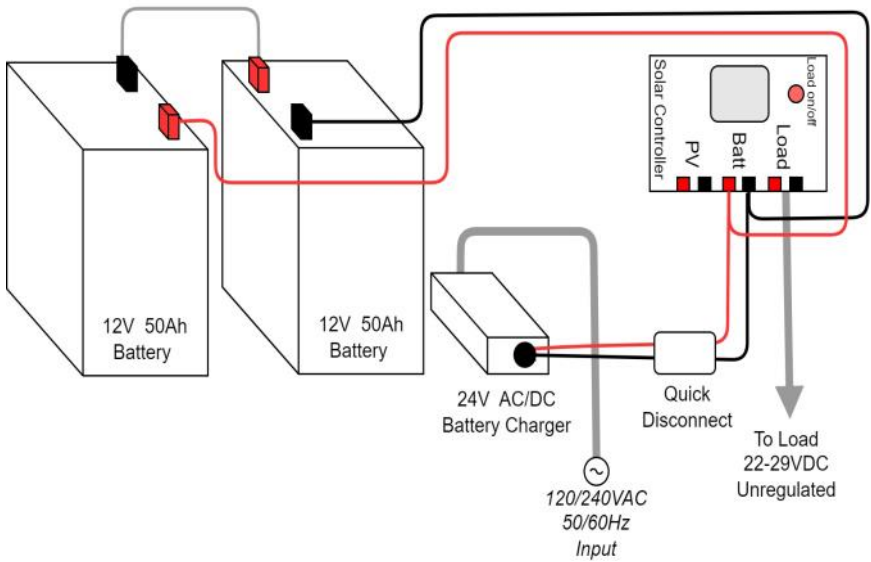

UPS-120 12V 1 Battery Configuration

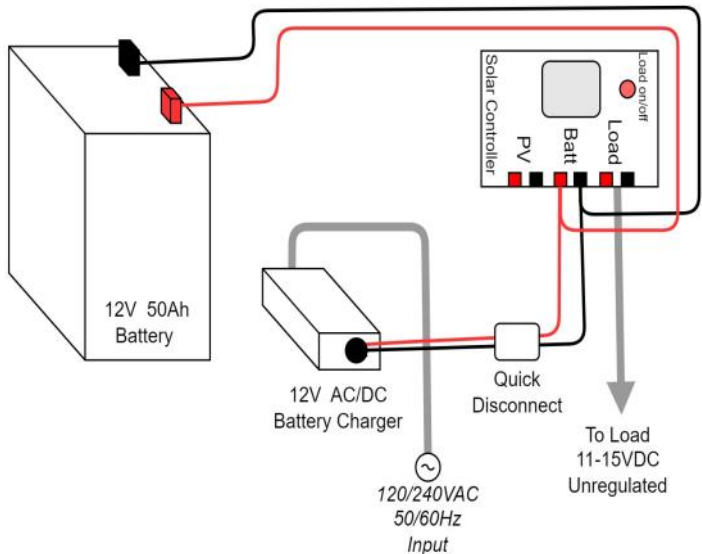

SPECIFICATION SUMMARY

Subject to change without notice

AGM Battery Model #	Battery Voltage	Battery Capacity	Storage Capacity	Backup Time at 25W Avg Load
UPS-PL12-50-120	12VDC	50Ah	600Wh	12hrs
UPS-PL24-100-120	24VDC	100Ah	1200Wh	24hrs

Lithium Battery Model #	Battery Voltage	Battery Capacity	Storage Capacity	Backup Time at 25W Avg Load
UPS-PL12-50L-120	12VDC	50Ah	600Wh	20hrs
UPS-PL24-100L-120	24VDC	100Ah	1200Wh	38hrs

NOTES

Limited Warranty

The UPSPro® products are supplied with a limited 36 month warranty which covers material and workmanship defects. This warranty does not cover the following:

- Parts requiring replacement due to improper installation, misuse, poor site conditions, faulty power, etc.
- Lightning or weather damage.
- Physical damage to the external & internal parts.
- Products that have been opened, altered, or defaced.
- Water damage for units that were not mounted according to user manual.
- Usage other than in accordance with instructions and the normal intended use.

NOTES