



RPSTL12/24

RemotePro[®]

Remote Power System

- Wireless Base Stations and Client Devices
- Surveillance Cameras
- Remote Sensors
- Remote Lighting
- Off Grid Electronics



Congratulations! on your purchase of the RemotePro[®] off-grid remote power system. Please take a moment to review this Qwik Install Guide before assembly or battery installation.



DANGER! Avoid Powerlines!

You Can Be Killed!

When following the instructions in this guide take extreme care to avoid contact with overhead power lines, lights and power circuits. Contact with power lines, lights or power circuits may be fatal. We recommend to install no closer than 20 feet to any power lines.

Safety: For your own protection, follow these safety rules.

- **Perform as many functions as possible on the ground**
- **Do not attempt to install on a rainy, windy or snowy day or if there is ice or snow accumulation at the install site or if the site is wet.**
- **Make sure there are no people, pets, etc. below when you are working on a roof or ladder.**



Recommended Tools: Phillips & Flat Screwdriver, 17/13/10mm wrench, 8mm nut driver



Please help preserve the environment and return used batteries to an authorized depot

Qwik Install

STEP 1: Prepare the enclosure: Install DIN rail (if required) to door using two phillips head screws. Install just the top mounting bracket to the enclosure using two 8mm bolts.

NOTE: It takes two people to mount the enclosure to a pole. The standard U-Bolt mounting accommodates a pole up to 4" diameter. Multiple pole straps can be used for extra strength. Pole straps are available for poles up to 11" diameter or larger.

STEP 2: Install the bottom bracket and stabilizer bracket to the pole using U-Bolt and/or Pole Straps. The stabilizer bracket is used as an aid to mounting and additional support when mounted.

STEP 3: Lift the enclosure and place it on the stabilizer bracket. Connect the top bracket to the pole using U-Bolt and/or Pole Straps.

STEP 4: Attach The two 8mm bolts that hold the bottom bracket to the enclosure. Make sure all bolts are tight. (8-15 ft lbs)

STEP 5: Install the three wire feedthru cable glands in the holes in the bottom of the enclosure. If one or more of the cable glands will not be used, just cut a short piece of wire and tighten in the cable gland.

NOTE: The bottom plate can be removed from the enclosure if you need to add some additional feedthru. (ex; conduit connection)

STEP 6: Install the batteries in the enclosure. For 12VDC the batteries are connected in parallel and for 24V the batteries are connected in series pairs. (See wiring diagram).

NOTE: The enclosure has slot features that can be used to strap the batteries if desired. Tycon[®] has velcro straps available. It takes two straps per battery.

STEP 7: Before attaching the battery cables to the

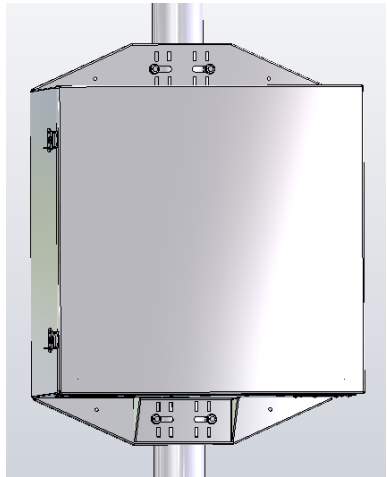
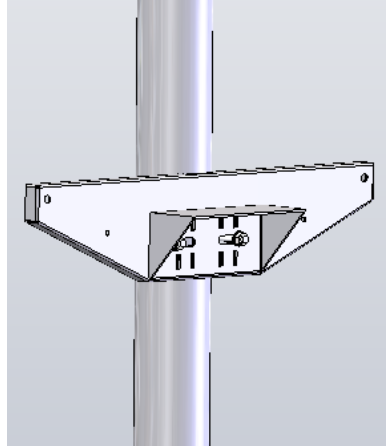

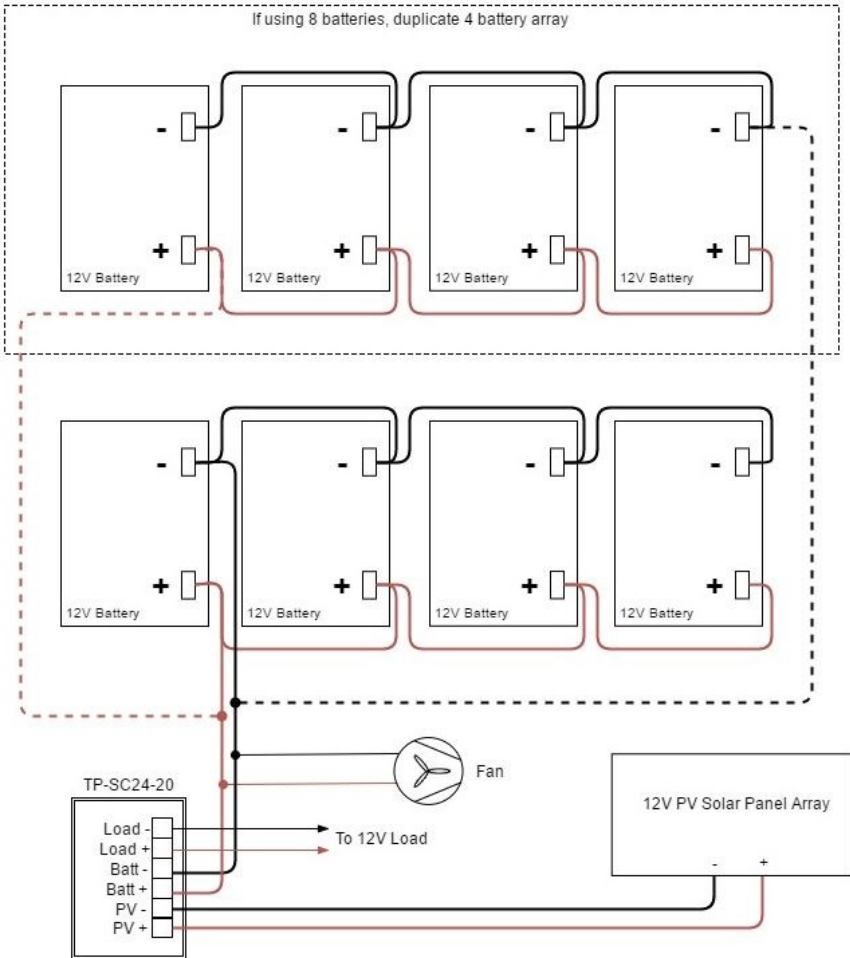

RPSTL 12V Wiring Diagram

batteries, first remove the battery cable fuse. This will prevent accidental short circuit.

Connect all battery - connections, then connect all battery + connections.

STEP 8: Attach the green DIN Rail adapters to the Solar Controller using one screw and mount to one of the DIN rails inside the front of the enclosure.



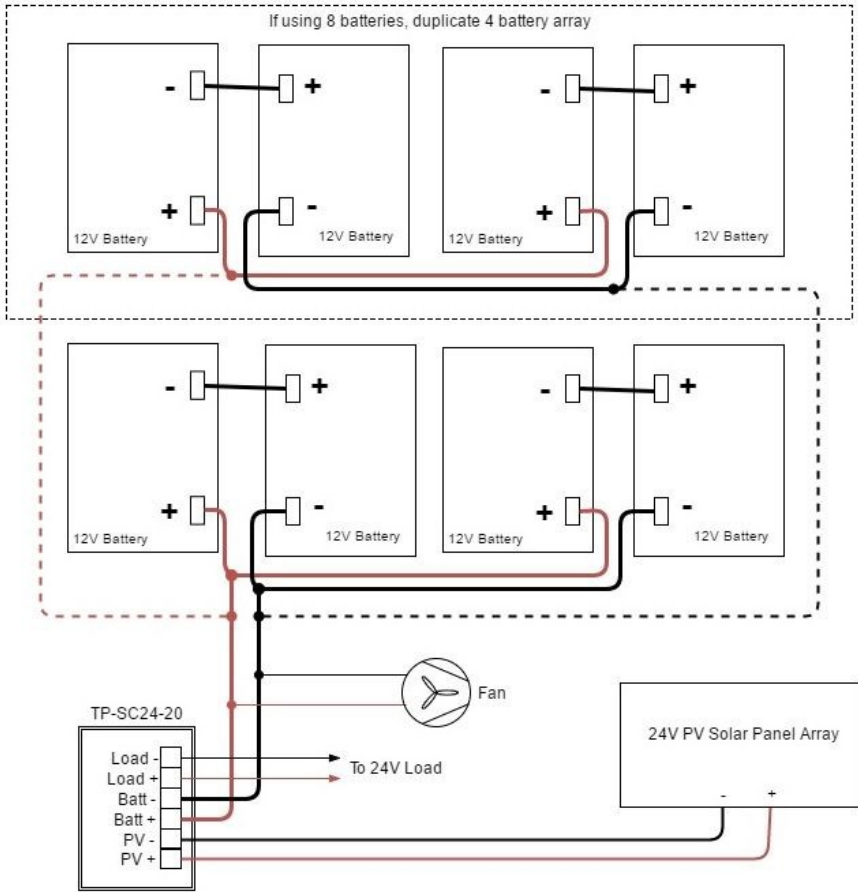

RPSTL 24V Wiring Diagram

STEP 9: Attach the solar panels to the solar panel mount so that the wire junction box is towards the inside. Remove the cover from the solar panel junction box by releasing the snaps with a small flat blade screwdriver. Connect the wires to the + and - screws inside the junction box. Clean the gasket and replace the cover making sure it is fully snapped in place.

STEP 10: Wire the solar panels in a 12V or 24V configuration. They will be wired in parallel for 12V and series pairs for 24V. The solar panel voltage configuration must match the battery configuration, either both 12V or both 24V. (See wiring diagram below)

NOTE: It's a good practice to mount the enclosure under the shade of the solar panel array to help keep the electronics and batteries as cool as possible. This will extend the useable life.

Panels without pre-installed MC-4 Connectors Configurations using PWM Controller

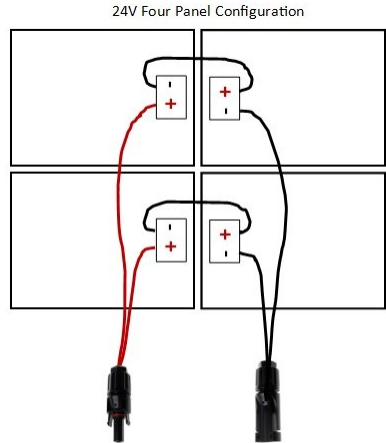
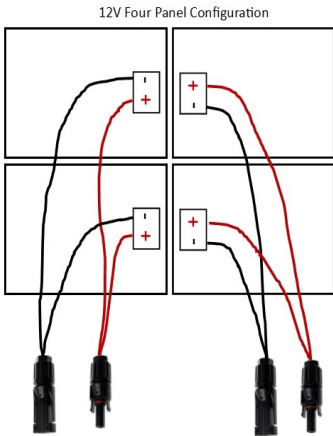

MC-4 Connectorized Panels 12V Wiring Configurations using PWM Solar Controller

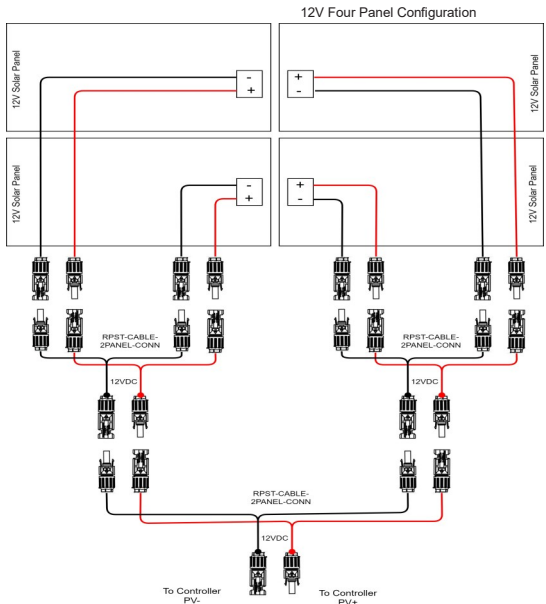
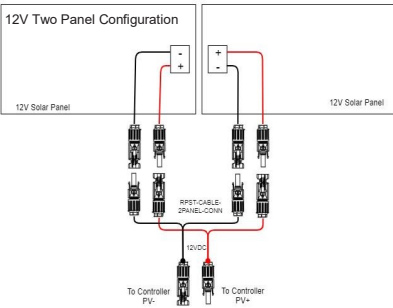

MC-4 Connectorized Panels 24V Wiring Configurations using PWM Solar Controller

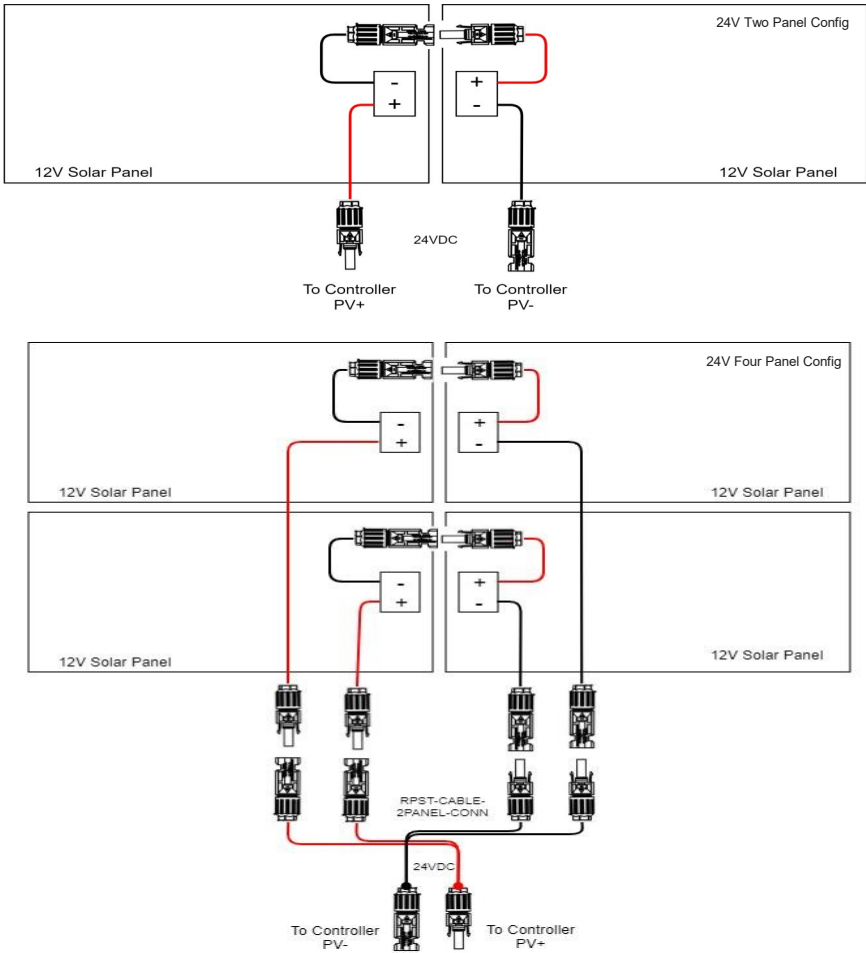

STEP 11: Connect the fan wires and battery wires to the solar controller BATT inputs. Connect the load to the controller LOAD outputs. Be sure to pay strict attention to polarity. **CAUTION: Wiring with a reverse polarity can cause equipment damage.**

Replace the fuse in the battery cable(s) to power up the controller.

NOTE: It's a good practice to always connect the battery first to the controller and disconnect the battery last. You can disconnect the battery by removing the fuse.

STEP 12: Route the long solar panel cable through one of the feedthru in the bottom of the enclosure. This cable can be cut to length. The shorter the cable, the lower the cable losses. Connect the cable - wire the Solar Controller PV - input. Connect the cable + wire to the solar

controller PV + input. Be sure to pay strict attention to polarity. **CAUTION: Wiring with a reverse polarity can cause equipment damage.**

NOTE: You can lengthen the solar cable if necessary. Use 12AWG or larger cable. Increasing cable length will increase cable loss.

STEP 13: Connect the Solar Panel cable from the solar controller to the connectors from the solar panel. Connect - first and + second.

STEP 14: Tighten all wire feedthrus. If they don't tighten on a small diameter wire, you can wrap some electrical tape around the wire in the seal area to increase its diameter and make a better seal.

STEP 15: Make sure the enclosure door gasket is clean, then close the door making sure all wires are clear. The enclosure can be locked using a standard combination or keyed pad lock.

TECH CORNER

Additional Information you may find useful

1. **CONTROLLER:** The 12V controller turns off power to the load at 11V and automatically reconnects when the battery reaches 12.5V. The 24V controller turns off power at 22V and automatically reconnects at 24.5V. This protects battery from overdischarge and increases battery life and performance. The button on the controller will allow for manual shut down of the load power. Maximum load current is 20A.

2. **Fuse:** The fuse is in line in the battery cables. If fuse is blown there was some sort of short in the battery connection and the controller will appear dead. Replace with 3AG 6.3 x 32mm 30A Slo-Blo fuse..

3. **VENTING:** The enclosure is vented thru a thermostatically (45C) controlled fan and top and bottom vents. The vents are covered with dust/insect filters. You should add the checking/cleaning of the filters during any routine maintenance cycle but at least annually.

4. **BATTERY MAINTENANCE:** The batteries used in the Remote Pro systems don't require any maintenance. They should last up to 5 years in normal use. **Note: Never store batteries for a long time in a discharged state or it may kill the battery. Especially in cold weather.**

5. **SOLAR PANEL TILT:** There is a solar panel tilt calculator at the Tycon Systems® website <http://tyconsystems.com>. We recommend using a fixed tilt and setting to optimize for winter sun. The panel should face South if you are in the Northern Hemisphere and face North if you are in the Southern Hemisphere. Some typical winter tilt angles are as follows:

<i>Place</i>	<i>Optimum Winter Tilt</i>
Houston / Cairo	56 deg
Albuquerque / Tokyo	60.5 deg
Denver / Madrid	65 deg
Minneapolis / Milano	69.5 deg
Winnipeg / Prague	74 deg

6. BATTERY OVERDISCHARGE: We highly recommend hooking all equipment loads to the controller load output. This output will disconnect the load if the battery voltage drops below 11V (22V if in a 24V system) and this will protect the battery from over-discharge. If batteries get completely discharged because the equipment was connected directly to the battery, you will reduce the battery life and you will most likely need to recondition them with a good quality 10A automotive battery charger. Once they are back to a normal operating range, the integrated charge controller will maintain the charge. Don't charge batteries using an automotive charger for longer than 24hrs or you may damage the battery.

7. TROUBLESHOOTING:

A. *The lights on the solar controller look fine but the batteries aren't charging?* The battery voltage and solar panel voltage must match. Check to make sure Solar Panels are wired in series for 24V if batteries are 24V or wired in parallel for 12V if batteries are 12V.



SPECIFICATIONS

Subject to change without notice

	RPSTL12-200-320	RPSTL12-400-320	RPSTL24-100-320	RPSTL24-200-320
Battery Capacity	200Ah	400Ah	200Ah	400Ah
Rated Load w/ 6Hrs Peak Sun	65W	80W	65W	80W
Reserve Power @ Rated Load	>24 hours	>30 hours	>24 hours	>30 hours
Load Voltage (DC)	11-15V 20A			
Battery Voltage (DC)	12V			
Battery Type	Valve Regulated Sealed Lead Acid / AGM			
Battery Life	5 Years			
Controller Type	12V/24V 20A PWM			
Overcharge Protection	14.4V			
Over-discharge protection	11V			
Over-discharge recovery volts	12.5V			
Controller Self Consumption	<0.3W			
Enclosure Type	Powder Coat Steel			
Operating Temperature	-30°C to +60°C			

- B. *There is no LOAD light and no voltage output?*** If battery voltage is too low the charge controller will turn off the load outputs. On a 12V battery system the load will turn off if battery is <11V. On a 24V battery system the load will turn off at <22V.
- C. *Why is my solar panel voltage so high?*** Open circuit voltage on a 12V panel is around 23V, and about 40V on a 24V panel. Once you connect to the charge controller the panel voltage will be reduced to a little higher than the battery voltage.
- D. *My system turns off at night and comes back on in the morning?*** This is a sure sign that the solar panels and/or battery capacity can't support the load. You should measure your actual load and recalculate to make sure you have adequate solar and battery capacity. Make sure there is no shading of panel during the day.
- E. *There is no power at the solar controller?*** Check the battery cable fuse. Measure voltage at the solar control it should be >9V. If less than 9V then batteries will need to be charged with an external charger to bring the voltage up to operating range.

NOTES

Wind Turbine

A wind turbine is an excellent backup power source for solar powered remote power systems. When it's cloudy and stormy there is usually wind. A wind turbine can harness the power from this wind and help keep the batteries charged. The wind turbine connects to the batteries in parallel with the solar controller.



TPW-400DT-12/24 400W
12V/24V Wind Turbine

- Includes Integrated Controller with Dump Load
- Good low wind performance
- Self braking in high wind
- 110MPH survivability

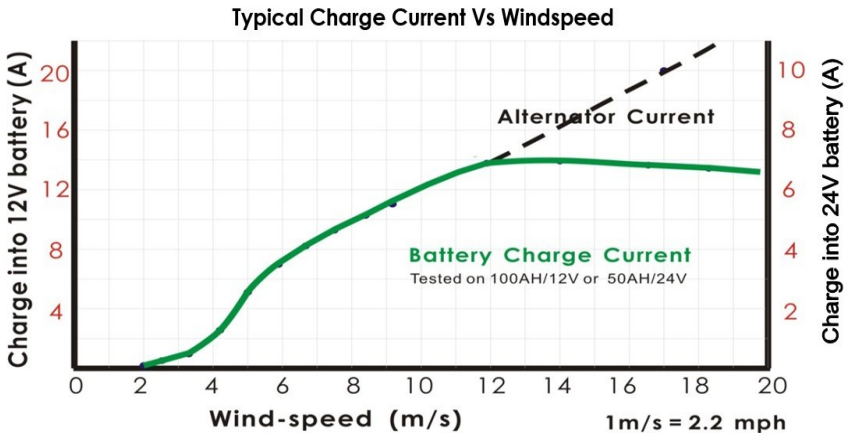

- Sealed and maintenance free

Replacement Parts

Solar Controller: TP-SC24-20

Batteries: TPBAT12-52

Solar Mount: TPSM-80X4-UNI

Solar Panel: TPS-12-85W

Limited Warranty

The RemotePro[®] products are supplied with a limited 36 month warranty which covers material and workmanship defects. This warranty does not cover the following:

- Parts requiring replacement due to improper installation, misuse, poor site conditions, faulty power, etc.
- Lightning or weather damage.
- Physical damage to the external & internal parts.
- Products that have been opened, altered, or defaced.
- Water damage for units that were not mounted according to user manual.
- Usage other than in accordance with instructions and the normal intended use.

Tycon Systems
14641 S 800 W
Bluffdale, UT 84065
support@tyconsystems.com
PH: 801-432-0003