



# User Guide

## BreezePro®

### TPW-400DT 12/24V 400W Wind Turbine

#### A. NOTICE

1. This information is believed to be reliable; however, We assume no responsibility for inaccuracies or omissions. The user of this information and product assumes full responsibility and risk.
2. All specifications are subject to change without notice.
3. Wind turbines must be installed following the guidelines of local regulations.

#### B. SAFETY PRECAUTIONS (Important)

1. Safety must be the primary concern as you plan the location, installation and operation. Please be aware of electrical, mechanical and blade hazards.
2. DO NOT install the turbine where anyone could approach the blades.
3. Use common sense and be careful.
4. Select the correct wire size, and the correct fuse size.
5. When installing, please make sure that the wind turbine is disconnected from the batteries.
6. Do not let the blades spin freely until the turbine is mounted on the pole.
7. Never approach the turbine during operation.
8. **The edges of the blades are very sharp, please be careful.**

#### C. About BreezePro®

1. This wind turbine has an embedded PWM charge controller with dump load. It controls battery charging and protects the wind turbine in high winds.
2. This wind turbine is designed to charge 12V or 24V Lead-Acid battery, specifically AGM or GEL sealed lead acid batteries. It is 12V/24V auto select. It can only work with 12V or 24V battery. Please **DO NOT** connect it to other battery voltages.
3. When connecting to the battery, please make sure that:  
the RED wire (+) of the wind turbine connects to battery V+ (positive);  
the BLUE wire (-) of the wind turbine connects to battery V- (negative).
4. Never allow a short between red and blue wires when the turbine is rotating.
5. Incorrect battery voltage or incorrect wire connection may damage the wind turbine internal controller, and these are not covered by the warranty.

#### D. Package content and specification

##### D.1 Package Contents

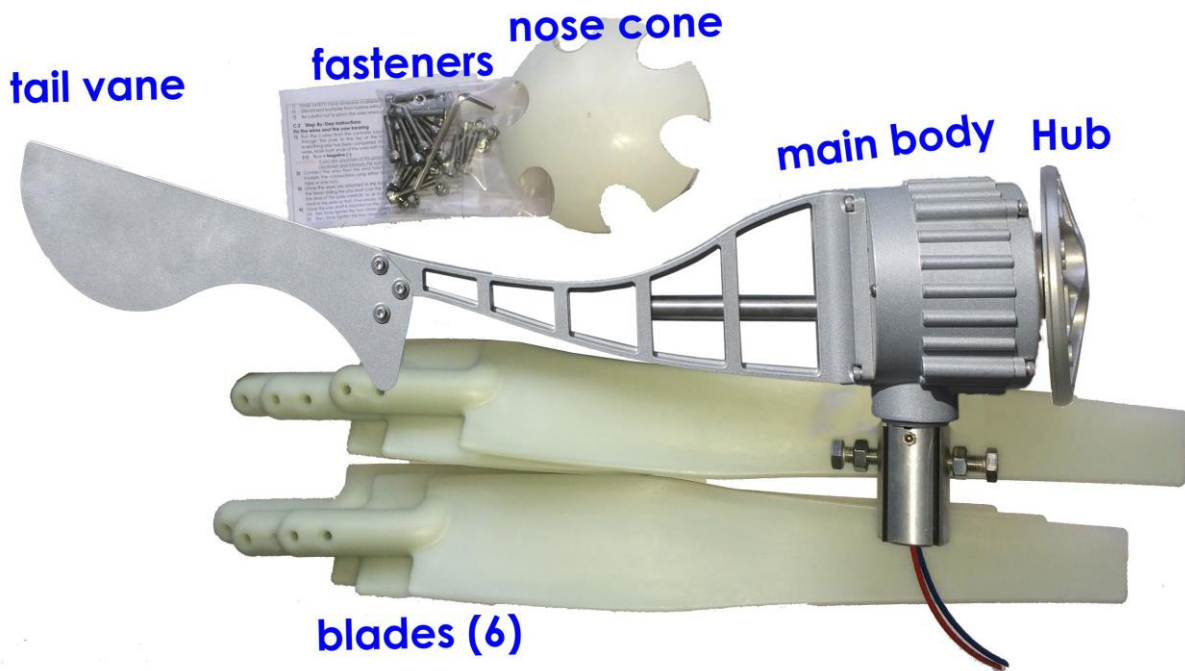

Figure 1: Package list

BreezePro® is shipped partially disassembled. Please compare the parts shown above to ensure that all necessary parts are included.

1	Mainbody	1	Fastener	Pcs	
2	Hub	1	M14 Nut	1	for Hub
3	Nose Cone	1	Φ2.5 Cotter Pin	1	for Hub
4	Blade	6	Φ6*25 Screw	12	for Blades
5	Tail Vane	1	Φ6*20 Screw	3	for Tail Vane
6	Manual	1	M6 Gasket	3	for Tail Vane
			M6 Nut (Nyloc)	15 + 2(spare)	for Blades & Tail
7	Fastener & Tools	→	5mm Hex Key	1	

## D.2 Specification

Rotor Diameter	1.2M
Net Weight	7.8Kg
Cut-in Wind Speed	2.1M/S
Rated Power	250W
Max Power	400W
Pole Dimensions	Inner Diameter 41mm
Package Weight	9.5Kg

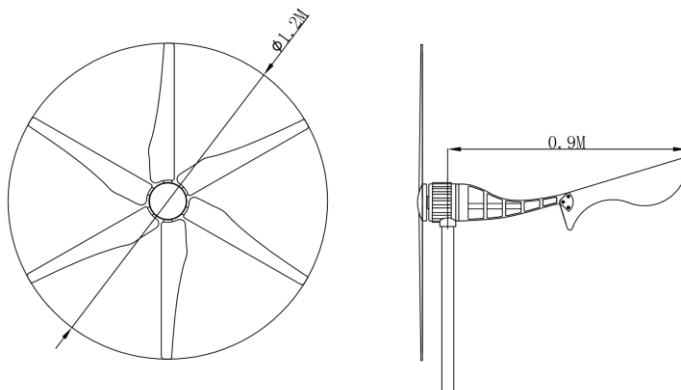

Figure 2: Specification

## E. Prepare for installation

E.1 The following general tools may be required for installing: Multi-meter, Wrench or spanner, Soldering iron, Screw driver, Heat shrink or electrical tape

### E.2 Pole or Mast

1. BreezePro® is designed to mount to an aluminum or steel tube with an inside diameter of 41mm. An inside diameter 41mm (1.6" or 15/8") steel pole is readily available (water pipe or scaffold tube). Please do not use plastic pipe.
2. A suitable mounting pole can be erected using a 6 meter galvanized pipe supported by 3 or 4 guy wires (Refer to [Figure 5](#)).
3. Make sure a minimum 50mm clearance is provided between the blade tips and any obstructions (Refer to [Figure 3](#)).
4. Mark and centre-punch two positions diametrically opposite, at 90° to the pipe seam, 20mm from top of the pipe (Refer to [Figure 4](#)). Then drill two 12mm diameter holes.

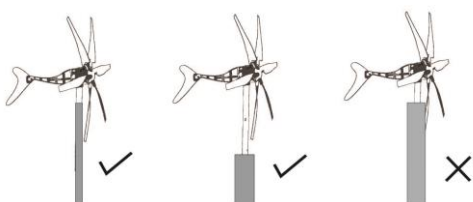
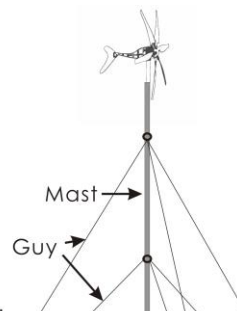

Figure 3: The clearance between the blade and pole



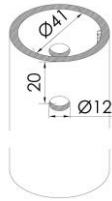

Figure 4: Mounting holes in pipe

Figure 5: Mounting using guy wires

### E.3 Wire

If the cross section area of the wires is NOT sufficient, the wires will heat up and could create a fire hazard. Please choose the right size of wire.

Minimum Wire Size (X-Section Area):

Distance From Batteries to Turbine	0-10M	10-20M	20-30M	30-50M
Wire X-Section Area for 12V Battery	12AWG	10AWG	9AWG	8AWG
Wire X-Section Area for 24V battery	14AWG	12AWG	10AWG	9AWG

### F. Installation

F.1 Please follow these precautions during the installation:

1. THINK SAFETY! Have someone available to help when installing.
2. Disconnect batteries from turbine.
3. Be careful not to pinch the wires when attaching the turbine to pole.

F.2 Step-By-Step Instructions

F.2.1 Connect the wires and mount the turbine

1. Run the 2 wires from the battery location, through the pole to the top of it.

DO NOT connect the wires to the battery until everything has been completed.

Strip the insulation back from each side of wires. Mark both ends of the wires with tape to identify the polarity: **Red** = Positive (+); **Blue** = Negative (-).

**CAUTION:** If you are uncertain of the polarity of the wires, simply spin the rotor shaft clockwise and measure the voltage direction with a volt meter.

2. Connect the **Red** (+) and **Blue** (-) wires from the wind turbine to the wires from the battery location. Insulate the connections using either heat shrink tubing or a quality electrical tape or wire nuts.
3. Once the wires are attached to the BreezePro®, gently pull the wires down through the mount pole sliding the yaw shaft into the pipe. Slide the yaw shaft down inside the end of the pole carefully, so as not to pinch the wires. Leave enough slack in the wires so that, if necessary, the BreezePro® can be removed from the pole. Strain relieve the wires so the weight of the long wires isn't pulling on the red and blue turbine wires.
4. Once the yaw shaft is mounted in the pole,
  - a. First, firmly tighten the two 10mm **screws** with a wrench.
  - b. Then, firmly tighten the two 10mm **nuts**.

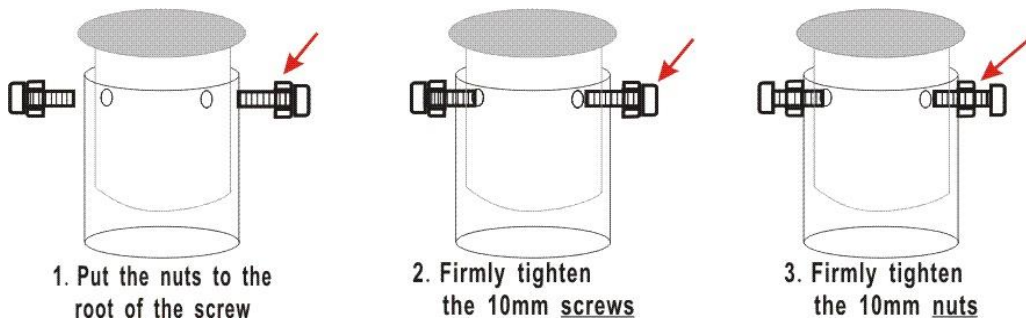

Figure 6

**CAUTION:** Make sure that your BreezePro® is securely attached to the pole. Remember that this attachment will have to hold in high winds.

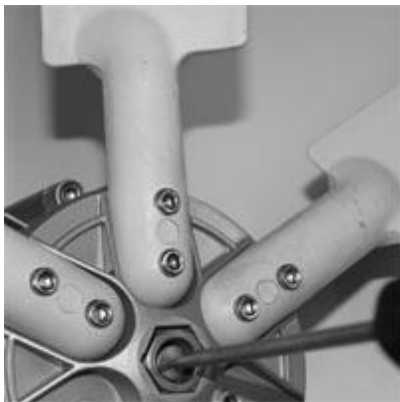

Figure 7.1: Blades & Hub



Figure 7.2: Cotter Pin



Figure 7.3: Fix the Tail Vane

## F.2.2 Fix the blades, the Hub and the tail

**CAUTION:** The edges of the blades are very sharp, please be careful.

1. Hold the shaft with a screw driver, turn the Hub counter-clockwise to remove the Hub from the shaft if necessary.
2. Attach the blades to the Hub.  
Securely tighten all the screws and nuts (Figure 7.1).  
**Make sure** every bolt on the blade is fully contact the nylon locker in the nut.  
Make sure the front face of the blade is toward the wind.
3. Put the M14 nut into the middle of the Hub, then put the Hub on the top of the rotor shaft. Hold the rotor shaft with a screw driver and turn the Hub **clockwise** to tighten the hub on the shaft (Figure 7.1).
4. Insert the cotter pin.  
Spread cotter pin (Figure 7.2).
5. Assemble the nose cone to the head of the shaft by snapping into place.
6. Attach the tail vane to the tail bracket, install the screws and nuts, tighten them firmly (Figure 7.3).

F.2.3 Connect the wires

1. Run the wires from the BreezePro® to the battery.
2. Attach wires to the battery.

Wind Turbine **Red** wire = Battery Positive (+);  
 Wind Turbine **Blue** wire = Battery Negative (-).

CAUTION: The BreezePro® may be damaged if the battery is connected with reverse polarity.

CAUTION: Never allow a short between red and blue wires.

CAUTION: DO NOT connect or disconnect the BreezePro® when the wind turbine blades are moving very fast. Wait for rotation to slow.

F.3 System wiring

Please refer to Figure 8 when wiring. Voltmeter (50V rated) and ammeter (20A rated) can be used to test the turbine and the charging. The fuse is 20A.

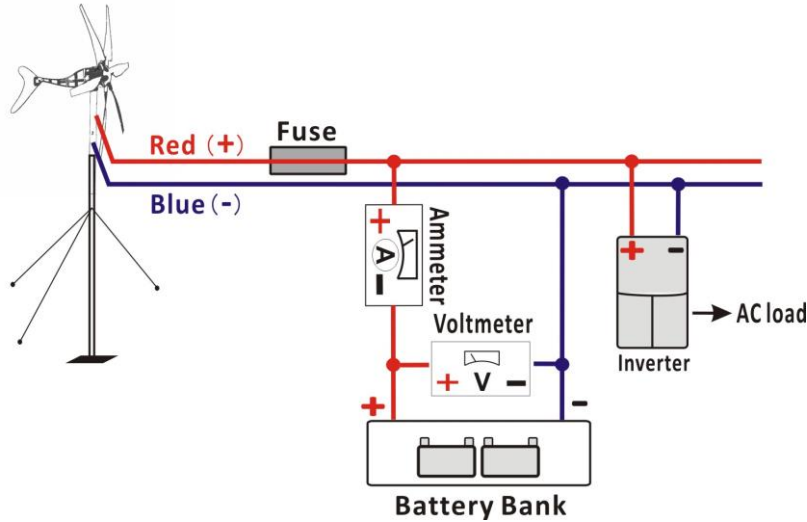

Figure 8: Connect the hybrid system

F.4 BreezePro® operation

Check support structures, blades, and electrical systems.

1. Do not let the rotor blades come in contact with a solid object. Use common sense about safety when locating the turbine.
2. Before you inspect the wind turbine or approach the path of the blades, disconnect the power leads from the battery. The wind turbine should slow down or stop spinning. Be very careful when working near a spinning turbine. Wait till the turbine stops spinning then tie one of the blades to the mounting pole using a rope or bungee.
3. NEVER allow a short between Red and Blue wires.  
If you want to stop charging, just disconnect the turbine from the battery. Use electrical tape to insulate the two output wires if necessary.
4. If no battery connection, the dump load on the wind turbine will be engaged and the turbine will be protected from over speed.
5. Note: The bearings in the turbine may require about 100 hours of operation in normal wind before they are running at peak efficiency. It is called 'break-in period'.
6. When expecting high winds such as from a Hurricane, it's best to remove the hub/blade assembly before the storm and then re-install after the storm passes. Removal is simple and involves only one cotter pin and one nut.

G. Additional Information

G.1 A larger system

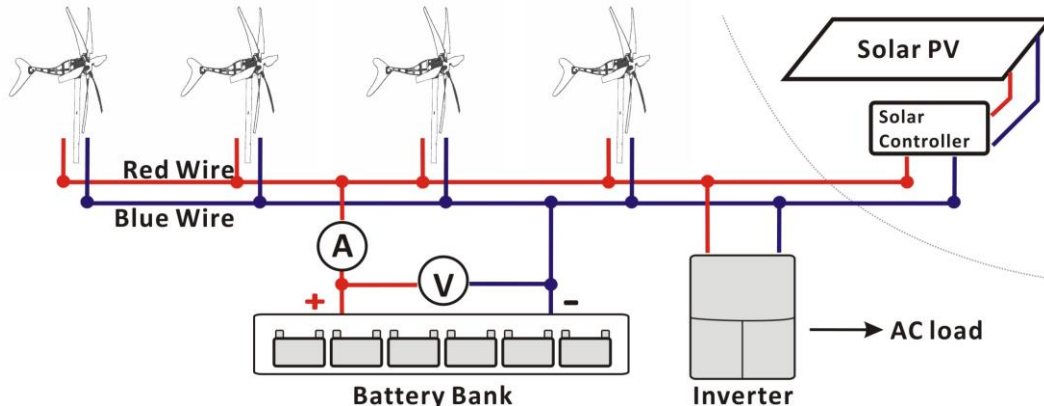

Figure 9: Connect a larger system

Multiple BreezePro®s can be run in a parallel fashion in order to increase the total power. This is an economical and reliable way to generate increased power if required. Hybrid solar/wind systems can also be created by adding a solar panel and solar controller.

G.2 How the embedded controller works:

1. The embedded PWM controller is mounted inside the turbine body. It continuously monitors and controls the output of the wind turbine to optimize battery charging and protect the wind turbine from over-speed.
2. The controller continually feeds any excess current to the embedded dump load located in the tail section of the turbine in order to control the wind turbine output and rotational speed.

CAUTION: *If the wind is strong, the dump load may get extremely hot. In order to avoid serious burns, never touch the dump load.*

G.3 Testing your BreezePro® - Manual Method

- a. When the BreezePro® is disconnected from a battery the controller switches in the dump load. This is a safety feature but makes the wind turbine harder to turn by hand.
- b. Disconnect the turbine from the battery and connect a voltmeter to the Red (+) and Blue (-) wires (Refer to [Figure 8](#)). Spin the turbine blades by hand and you should immediately see a voltage up to 20V on the voltmeter. Voltage will depend on rotation speed and will not be stable. This is normal. Voltage will only be seen when you first start to spin the blades. Very quickly, the controller will dump the power to the dump load and voltage output on the wires will fall to near zero.
- c. Connect the turbine to a 12V battery with an amp meter in line. Spin the turbine and measure the amps. You should see up to about 4-10A depending on the rotational speed and the battery charge condition.

G.4 Trouble shooting your BreezePro®

**Check all wiring and tighten all fasteners.**

If you can't determine cause of the problems, such as: big vibration; no output; very small output in large wind. Please:

1. Uninstall the wind turbine immediately and check if there is obvious damage on the shell, blades or yaw part.
2. Disconnect the wind turbine from the battery, spin the wind turbine and test the output voltage. This open-circuit voltage can easily exceed 12V but will only be seen for an instant before the controller routes the power output to the dump load.
3. Connect the turbine to the battery with an ampere meter, spin the turbine by hand or by tools, to see the charge current is OK.

*Figure 10: Typical Charge Current Vs Wind Speed*

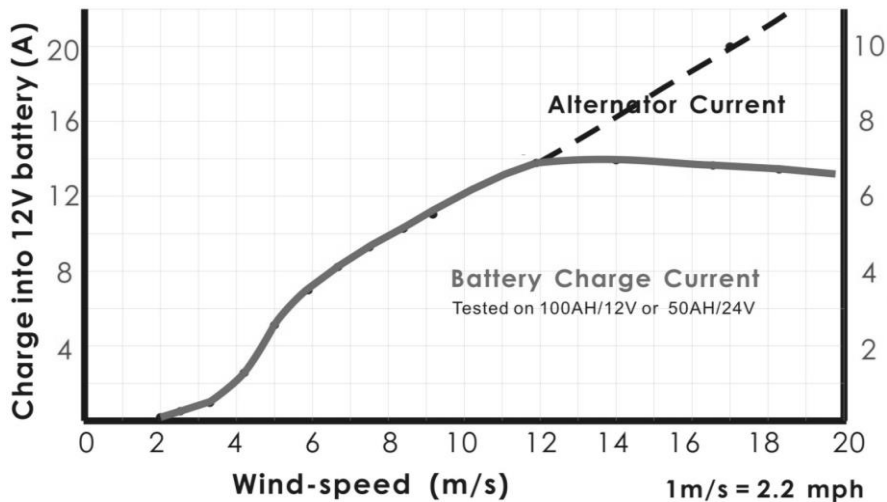

## Limited Warranty

Tycon Solar® BreezePro® wind turbines are supplied with a limited 24-month warranty which covers material and workmanship defects. This warranty does not cover the following:

- Parts requiring replacement due to improper installation, misuse, poor site conditions, faulty power, etc.
- Lightning damage.
- Physical damage to the external & internal parts.
- Products that have been opened, altered, or defaced.
- Units that were not properly grounded.
- Usage other than in accordance with instructions and the normal intended use.

Do not return any products until you receive a Return Material Authorization (RMA) number. Products received without a valid RMA number will be rejected and returned to sender.

## Warranty Repairs

All returns must have a valid RMA number written clearly on the outside of the box. Without an RMA number the shipment will be refused. For customers located in United States and Canada, customer pays all shipping charges incurred to ship the product to Tycon Systems®. Tycon Systems® pays shipping charges to return the product to the original purchaser. For all other countries, the original purchaser shall pay all shipping, broker fees, duties and taxes incurred in shipping products to and from Tycon Systems®. Provided the goods have not been modified or repair attempted by someone other than Tycon Systems®, at the option of Tycon Systems®, products may be returned either as repaired or replaced. If it is determined that there is no fault found (NFF) on a unit within warranty, the customer will be charged \$75 USD for testing time. For products out of warranty, the standard NFF charge is \$200. This charge will be at the discretion of Tycon Systems®. The RMA number is valid for 14 days from date of issue. The product must be received by the repair depot within these 14-days or the shipment may be refused.

## Shipping and Damage Claims

All shipping damage claims are the purchaser's responsibility.

Inspect each shipment upon delivery and IMMEDIATELY report all damage to the carrier. There may be time limits and inspections may be required.

phone: 801-432-0003

support@tyconsystems.com

8000022 Rev 10